

Amphenol

Ship Board Connectors
Ship Board 03 Rev. 02/24



Amphenol

TABLE OF CONTENTS	MIL Ref. No.	Page
Introduction		1
Performance Specification		2
Insert Arrangement		3
Wall Mount Receptacle Connector	(M28840/10)	4
In Line Receptacle Connector	(M28840/11)	5
Box Mount Receptacle Connector	(M28840/12)	6
Jam Nut Receptacle Connector	(M28840/14)	7
Plug Connector	(M28840/16)	8
Plug Connector With Straight Strain Relief Backshell	(M28840/17)	9
Plug Connector With 90° Strain Relief Backshell	(M28840/18)	10
Plug Connector With 45° Strain Relief Backshell	(M28840/19)	11
Receptacle Connector With Straight EMI/RFI Backshell	(M28840/20)	12-13
Receptacle Connector With Straight EMI/RFI Backshell	(M28840/21)	14-15
Plug Connector With Straight EMI/RFI Backshell	(M28840/26)	16-17
90° Adaptor Assembly Plug	(M28840/28)	18-19
Plug Connector With 45° EMI/RFI Backshell	(M28840/29)	20-21
Straight Strain-Relief Backshell	(M28840/1)	22
90° Strain-Relief Backshell	(M28840/2)	23
45° - Strain Relief Backshell	(M28840/3)	24
Back Shell For Metal Core Conduit	(M28840/5)	25-27
EMI/RFI Environmental Backshell	(M28840/6)	28-30
90° EMI/RFI Environmental Backshell	(M28840/8)	31-35
45° EMI/RFI Environmental Backshell	(M28840/9)	36-40
90° EMI Conduit Adaptor	(M28840/25)	41-43
45° EMI Conduit Adaptor	(M28840/27)	44-46
Metal Conduit Coupler Style A & B	(M28840/30)	47
E Nut	(M28840/23)	48
Dummy Stowage / Front Shell Receptacle	(M28840/7)	49
Protective Receptacle Cover	(M28840/13)	50
Protective Plug Cover	(M28840/15)	51
Mounting Gasket	(M28840/24)	52
Metal Conduit Bushing	(M28840/22)	53
Standard Duty Electrical Pin Contact	(M39029/83)	54-55
Standard Duty Electrical Socket Contact	(M39029/84)	56-57
Polarization Keyways And Panel Cut Out		58
Contact Insertion / Extraction Instructions		59-60
Contact Crimping, Insertion, Removal Tools		61

Overview

Amphenol is a leading manufacturer of connectors now offers complete line of M28840 circular connectors according to MIL-DTL -28840. These shipboard application connectors are precision-machined, highly reliable, and meet superior mechanical shock performances. These high-density connectors are designed and tested to withstand extreme environmental conditions and demanding applications. Amphenol also offer the full range of backshells to support this connector series.

Features

Precision-machined to MIL-DTL-28840 specification

Available in Nine shell sizes: 11, 13, 15, 17, 19, 23, 25, 29 & 33.

Pin count - 7, 12, 21, 31, 42, 64, 92, 121 and 155.

Plating options – Cadmium, Zinc Nickel & Tin Zinc.

Support connectors as well as kit with accessories.

Six keying options (1,2,3,4,5,6) for both plugs and receptacles.

Contact size is AWG 20 with wire accommodation options from AWG 20 to AWG 28.

Crimp termination, rear insert and front release contacts.

Complete line of straight, 90° and 45° backshells.

Benefits

Fully intermateable and interchangeable with any qualified M28840 connector manufacturer

Backshell designs for strain relief, EMI and environmental sealing.

Options to buy connector kitted with backshell and accessories.

Same application tool for all three types of contacts

Applications

- US Navy Shipboard surface craft and submarine
- Mission critical combat and communication systems
- Mobile tactical shelters electronic battlefield networks
- Mobile emergency telecommunications (MET) stations
- Deployable outdoors in harsh environments



IL - DTL - 28840 Shipboard Electrical Connectors (Performance Specifications)

Performance Specifications	
Current Rating (Max.)	Size # 20 contact 20AWG 7.5A, 22AWG 5.0A, 28AWG 1.5A, 30AWG 1.0A
Test Voltage (Dielectric Withstanding Voltage)	1000 VAC RMS at sea level, test per EIA-364-20
Insulation Resistance	5000 megohms min. (at ambient temp) per EIA-364-21
Contact Resistance	Per SAE-AS39029
Operating Temperature	-55°C to +200°C
Fluid Immersion	Per test method EIA-364-10
Shock	In accordance with MIL-S-901 grade A
Vibration	Per EIA-364-28 test procedure
Magnetic Permeability	2.0 μ (Aluminum) ASTM-A342/A342M

Materials & Finishes	
Shells, Coupling Nuts, Jam Nuts	Aluminum Alloy per ASTM B211, or Stainless Steel per AMS-QQ-S-763
Contacts	Copper Alloy, 50 μ inch Gold plated per ASTM B488 Type 3, Code C Class 1. 27 over nickel underplate per QQ-N-290 Class 2 Socket contact hood: Stainless Steel passivated
Insulators	High Grade Engineering Plastic
Contact Retention Clip	Beryllium Copper
Grommet Seal	Blended Elastomer

Contact Code	Type	Contact Specification	Contact Size	Acceptable Wire Size	Outside Dia. of Finished Wire	
					Min.	Max.
F	Pin	SAE-AS39029/83-508	20-20	24	1.02 (.040)	1.78 (.070)
G	Socket	SAE-AS39029/84-509		22		
P	Pin	SAE-AS39029/83-450	20-22	20		
S	Socket	SAE-AS39029/84-452		26		
D	Pin	SAE-AS39029/83-451	20-28	24		
E	Socket	SAE-AS39029/84-453		22		

Note:
Wire must be used in accordance with MIL-DTL-16878 to achieve sealing.
All dimensions are in mm (inches).



Shell Size 11
7 Contacts

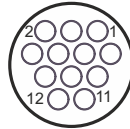

Shell Size 13
12 Contacts

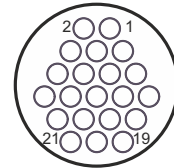

Shell Size 15
21 Contacts

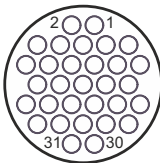

Shell Size 17
31 Contacts

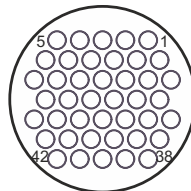

Shell Size 19
42 Contacts

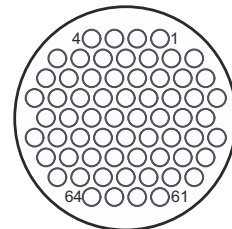

Shell Size 23
64 Contacts

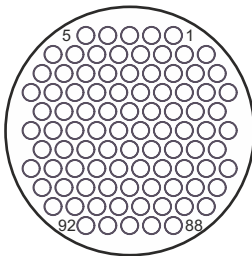

Shell Size 25
92 Contacts

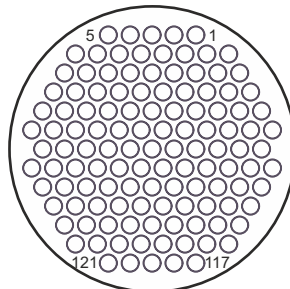

Shell Size 29
121 Contacts

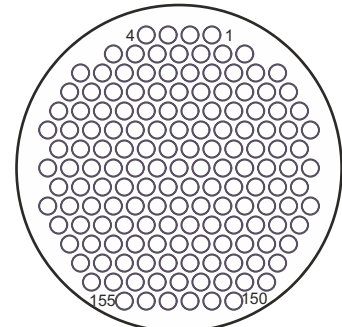

Shell Size 33
155 Contacts

Layouts Per MIL-STD-1698

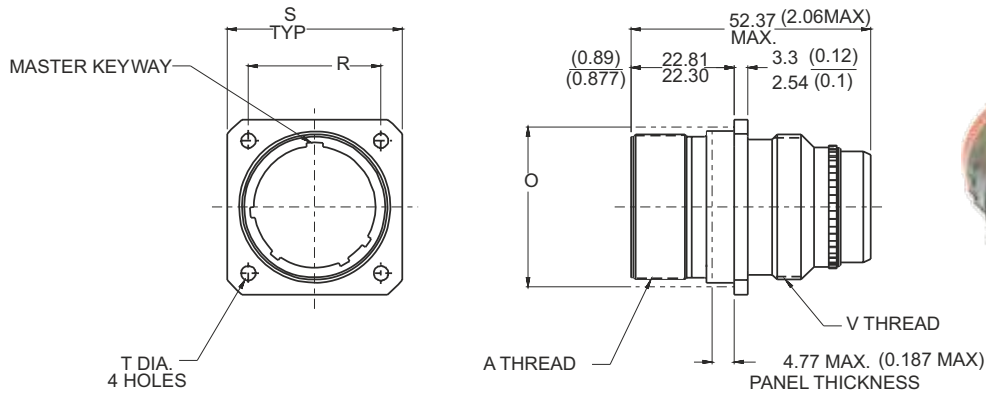
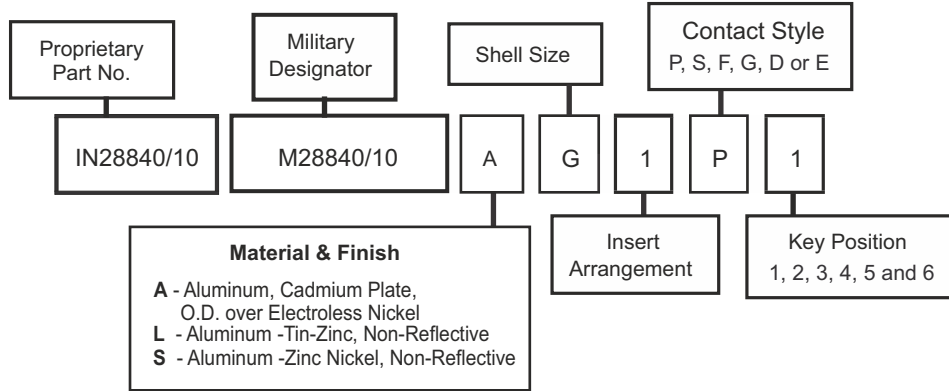

Military Shell Size	Shell Size	A Thread Class 2A	V Thread Class 2A	Ø Ref. Mtg. Hole	R True Position \varnothing to \varnothing	S	T Diameter
A	11	.750-.1P-.2L-D.S.	.750-20 UNEF	(.812) 20.62	(.750) 19.05	(1.043) 26.49 (1.003) 25.48	(.130) 3.30 (.115) 2.92
B	13	.875-.1P-.2L-D.S.	.875-20 UNEF	(.937) 23.80	(.843) 21.41	(1.158) 29.41 (1.118) 28.40	
C	15	1.062-.1P-.2L-D.S.	1.000-20 UNEF	(1.124) 28.55	(.968) 24.59	(1.278) 32.46 (1.238) 31.45	
D	17	1.125-.1P-.2L-D.S.	1.125-18 UNEF	(1.187) 30.15	(1.01) 25.78	(1.403) 35.64 (1.363) 34.62	
E	19	1.312-.1P-.2L-D.S.	1.250-18 UNEF	(1.374) 34.90	(1.140) 28.96	(1.528) 38.81 (1.488) 37.80	
F	23	1.500-.1P-.2L-D.S.	1.437-18 UNEF	(1.562) 39.67	(1.281) 32.54	(1.738) 44.15 (1.698) 43.13	
G	25	1.625-.1P-.2L-D.S.	1.562-18 UNEF	(1.687) 42.85	(1.392) 35.36	(1.838) 46.69 (1.798) 45.67	(.157) 3.99 (.142) 3.61
H	29	1.812-.1P-.2L-D.S.	1.875-16 UN	(1.874) 47.60	(1.568) 39.83	(2.158) 54.81 (2.118) 53.80	
J	33	2.000-.1P-.2L-D.S.	2.062-16 UNS	(2.062) 52.37	(1.734) 44.04	(2.348) 59.64 (2.308) 58.62	

Note: All dimensions are in mm (inches)

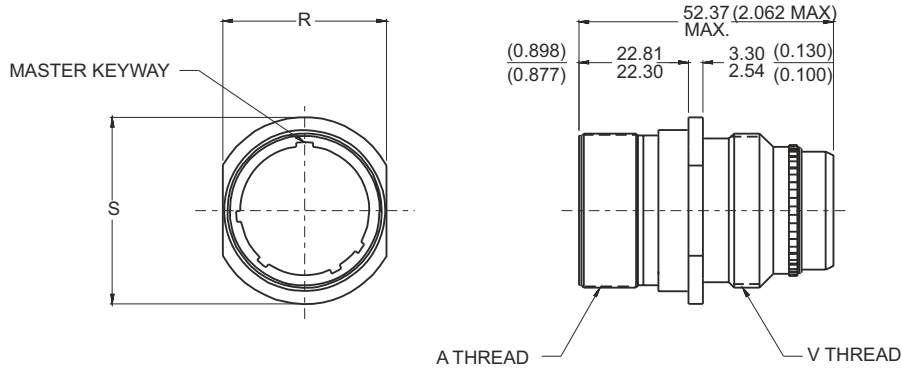
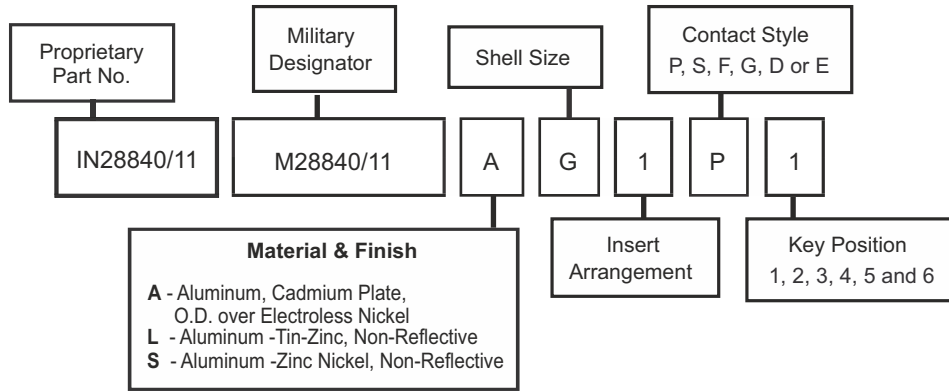

Military Shell Size	Shell Size	A Thread Class 2A	V Thread Class 2A	R	S Diameter
A	11	.750-.1P-.2L-D.S.	.750-20 UNEF	(.768) 19.51 (.758) 19.25	(.963) 24.46 (.943) 23.95
B	13	.875-.1P-.2L-D.S.	.875-20 UNEF	(.893) 22.68 (.883) 22.43	(1.088) 27.63 (1.063) 27.13
C	15	1.062-.1P-.2L-D.S.	1.000-20 UNEF	(1.080) 27.43 (1.070) 27.18	(1.275) 32.38 (1.255) 31.88
D	17	1.125-.1P-.2L-D.S.	1.125-18 UNEF	(1.143) 29.03 (1.133) 28.78	(1.338) 33.98 (1.318) 33.48
E	19	1.312-.1P-.2L-D.S.	1.250-18 UNEF	(1.330) 33.78 (1.320) 33.53	(1.525) 38.74 (1.505) 38.23
F	23	1.500-.1P-.2L-D.S.	1.437-18 UNEF	(1.518) 38.56 (1.508) 38.30	(1.713) 43.51 (1.693) 43.00
G	25	1.625-.1P-.2L-D.S.	1.562-18 UNEF	(1.643) 41.73 (1.633) 41.48	(1.838) 46.09 (1.818) 46.18
H	29	1.812-.1P-.2L-D.S.	1.875-16 UN	(1.893) 48.08 (1.883) 47.83	(2.088) 53.04 (2.068) 52.53
J	33	2.000-.1P-.2L-D.S.	2.062-16 UNS	(2.080) 52.83 (2.070) 52.58	(2.275) 57.78 (2.255) 57.28

Note: All dimensions are in mm (inches)

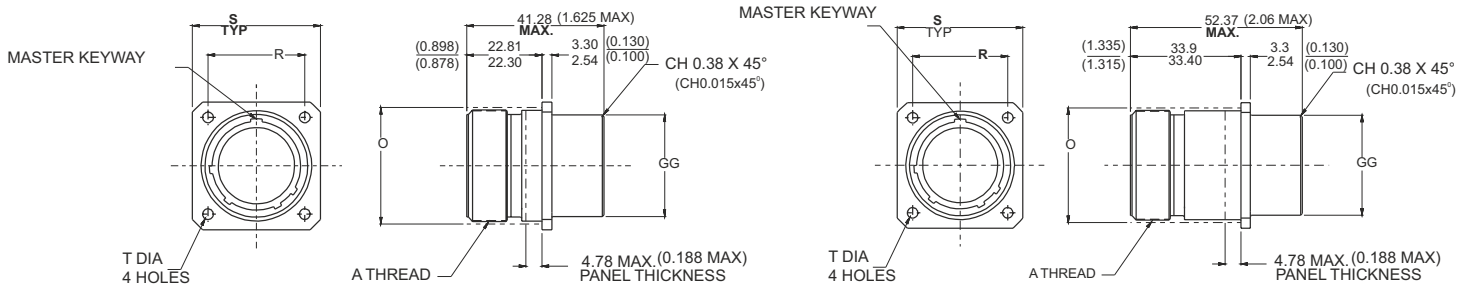
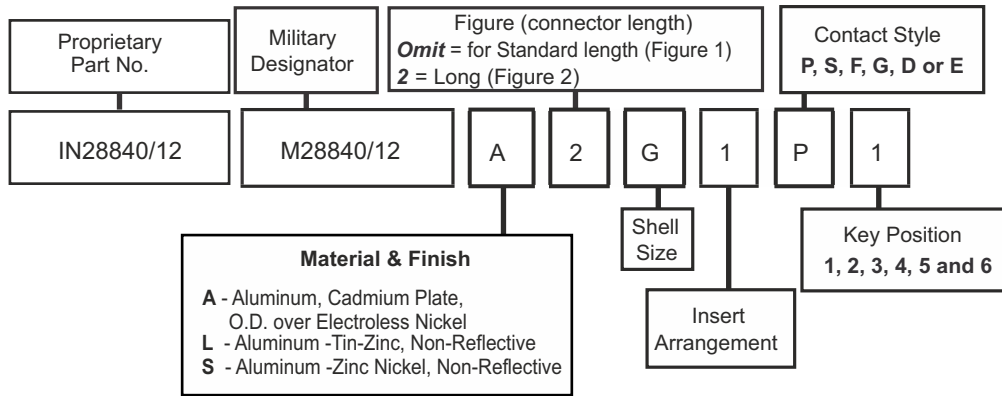
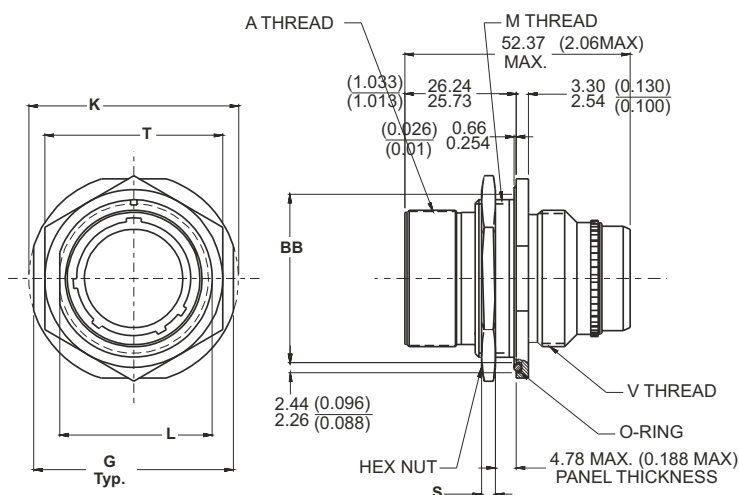
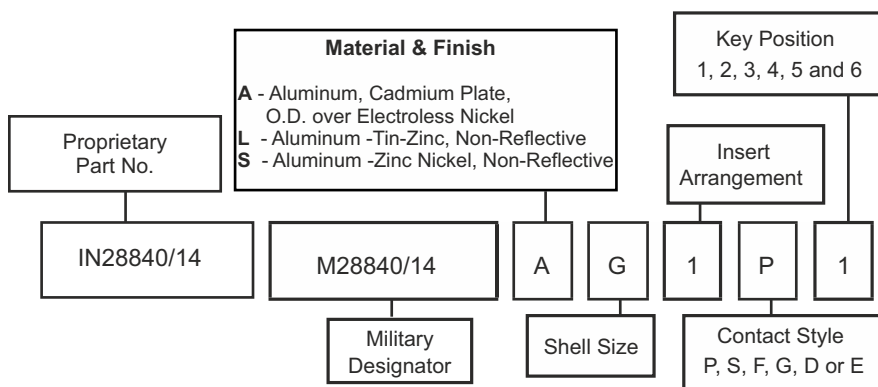

FIGURE 1
Standard, 41.28 max length
(1.625 MAX)

FIGURE 2
Long, 52.37 max length
(2.06 MAX)

Designator	N Diameter Max	O Reference Mating Hole	R True Position Centerline to Centerline	S	T	GG Diameter Max.
A (11)	(.750) 19.05	(.812) 20.62	(.750) 19.05	(1.043) 26.49 (1.003) 25.48	(130) 3.30 (115) 2.92	(.758) 19.25
B (13)	(.875) 22.22	(.937) 23.80	(.843) 21.41	(1.158) 29.41 (1.118) 28.40		(.880) 22.35
C (15)	(1.062) 26.97	(1.124) 28.55	(.968) 24.59	(1.278) 32.46 (1.238) 31.45		(1.005) 25.53
D (17)	(1.125) 28.58	(1.187) 30.15	(1.015) 25.78	(1.403) 35.64 (1.363) 34.62		(1.130) 28.70
E (19)	(1.312) 33.32	(1.374) 34.90	(1.140) 28.96	(1.528) 38.81 (1.488) 37.80		(1.255) 31.88
F (23)	(1.500) 38.10	(1.562) 39.67	(1.281) 32.54	(1.738) 44.15 (1.698) 43.13		(1.443) 36.65
G (25)	(1.625) 41.28	(1.687) 42.85	(1.392) 35.36	(1.838) 46.69 (1.798) 45.67		(157) 3.99 (142) 3.61
H (29)	(1.812) 46.02	(1.874) 47.60	(1.568) 39.83	(2.158) 54.81 (2.118) 53.80	(1.880) 47.75	
J (33)	(2.000) 50.80	(2.062) 52.37	(1.734) 44.04	(2.348) 59.64 (2.308) 58.62	(2.067) 52.50	

Note: All dimensions are in mm (inches)



Designator	BB	G	K	L Across Flat	M Thread Class 2A	N Max.	P	R Max.	S Hex Nut Thickness	T ±.017 (0.43)
A (11)	(.979) 24.87 (.969) 24.61	(1.274) 32.36 (1.254) 31.85	(1.368) 34.75 (1.348) 34.24	(.841) 21.36 (.832) 21.13	7/8-20 UNEF	(.750) 19.05	(.890) 22.61 (.880) 22.35	(.875) 22.22	(125) 3.17	(1.062) 26.97
B (13)	(1.104) 28.04 (1.094) 27.79	(1.399) 35.53 (1.379) 35.03	(1.508) 38.30 (1.488) 37.80	(.966) 24.54 (.957) 24.31	1-20 UNEF	(.875) 22.22	(1.015) 24.78 (1.005) 25.78	(1.000) 25.40		(1.188) 30.18
C (15)	(1.292) 32.82 (1.282) 32.56	(1.587) 40.31 (1.567) 39.80	(1.681) 42.70 (1.661) 42.19	(1.156) 29.29 (1.144) 29.06	1 3/16-18 UNEF	(1.062) 26.97	(1.203) 30.56 (1.193) 30.30	(1.188) 30.18		(1.375) 34.93
D (17)	(1.354) 34.39 (1.344) 34.14	(1.649) 41.88 (1.629) 41.38	(1.743) 44.27 (1.723) 43.76	(1.216) 30.89 (1.207) 30.66	1 1/4-18 UNEF	(1.125) 28.58	(1.265) 32.13 (1.255) 31.88	(1.250) 31.75		(1.438) 36.53
E (19)	(1.542) 39.17 (1.532) 38.91	(1.837) 46.66 (1.817) 46.15	(1.931) 49.05 (1.911) 48.54	(1.403) 35.64 (1.394) 35.41	1 7/16-18 UNEF	(1.312) 33.32	(1.453) 36.91 (1.443) 36.65	(1.438) 36.52		(1.625) 41.28
F (23)	(1.729) 43.92 (1.718) 43.66	(2.024) 51.41 (2.004) 50.90	(2.118) 53.80 (2.098) 53.29	(1.591) 40.41 (1.582) 40.18	1 5/8-18 UNEF	(1.500) 38.10	(1.640) 41.66 (1.630) 41.40	(1.625) 41.28		(1.812) 46.02
G (25)	(1.854) 47.09 (1.844) 46.84	(2.149) 54.58 (2.129) 54.08	(2.243) 56.97 (2.223) 56.46	(1.716) 43.59 (1.707) 43.36	1 3/4-18 UNS	(1.625) 41.28	(1.765) 44.83 (1.755) 44.58	(1.750) 44.45		(189) 4.8
H (29)	(2.042) 51.87 (2.032) 51.61	(2.337) 59.36 (2.317) 58.85	(2.435) 61.85 (2.415) 61.34	(1.903) 48.34 (1.894) 48.11	1 15/16-16 UN	(1.812) 46.02	(1.953) 49.61 (1.943) 49.35	(1.938) 49.22	(2.188) 55.58	
J (33)	(2.229) 56.62 (2.219) 56.36	(2.524) 64.11 (2.504) 63.60	(2.618) 66.50 (2.598) 65.99	(2.091) 53.11 (2.082) 52.88	2 1/8-16 UN	(2.000) 50.80	(2.140) 54.36 (2.130) 54.10	(2.125) 53.98	(2.375) 69.85	

Note: All dimensions are in mm (inches)

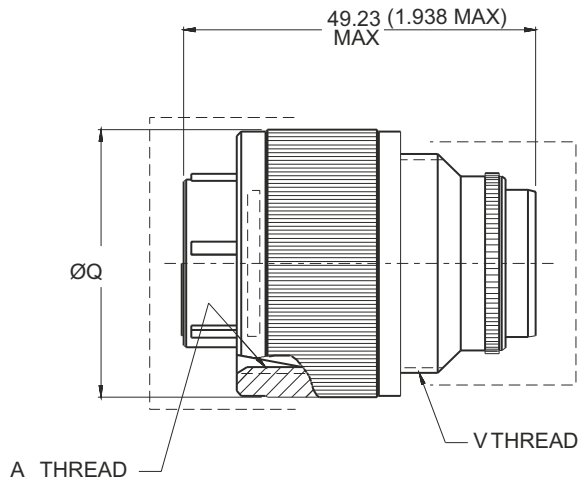
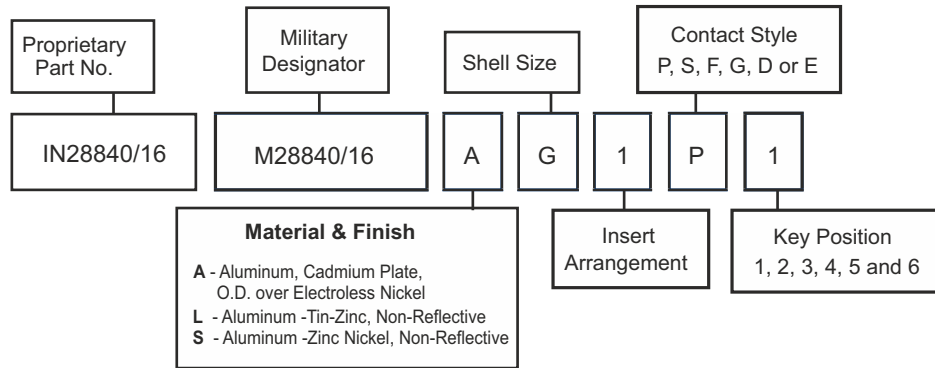

Designator	A Thread Class 2B	V Thread Class 2A	Ø Q Max.
A (11)	.750-1P-.2L-DS	3/4-20 UNEF	(1.028) 26.11
B (13)	.875-1P-.2L-DS	7/8-20 UNEF	(1.141) 28.98
C (15)	1.062-1P-.2L-DS	1-20 UNEF	(1.263) 32.08
D (17)	1.125-1P-.2L-DS	1 1/8-18 UNEF	(1.387) 35.23
E (19)	1.312-1P-.2L-DS	1 1/4-18 UNEF	(1.513) 38.43
F (23)	1.500-1P-.2L-DS	1 7/16-18 UNEF	(1.703) 43.26
G (25)	1.625-1P-.2L-DS	1 9/16-18 UNEF	(1.825) 46.36
H (29)	1.812-1P-.2L-DS	1 7/8-16 UN	(2.143) 54.43
J (33)	2.000-1P-.2L-DS	2 1/16-16 UNS	(2.329) 59.16

Note: All dimensions are in mm (inches)

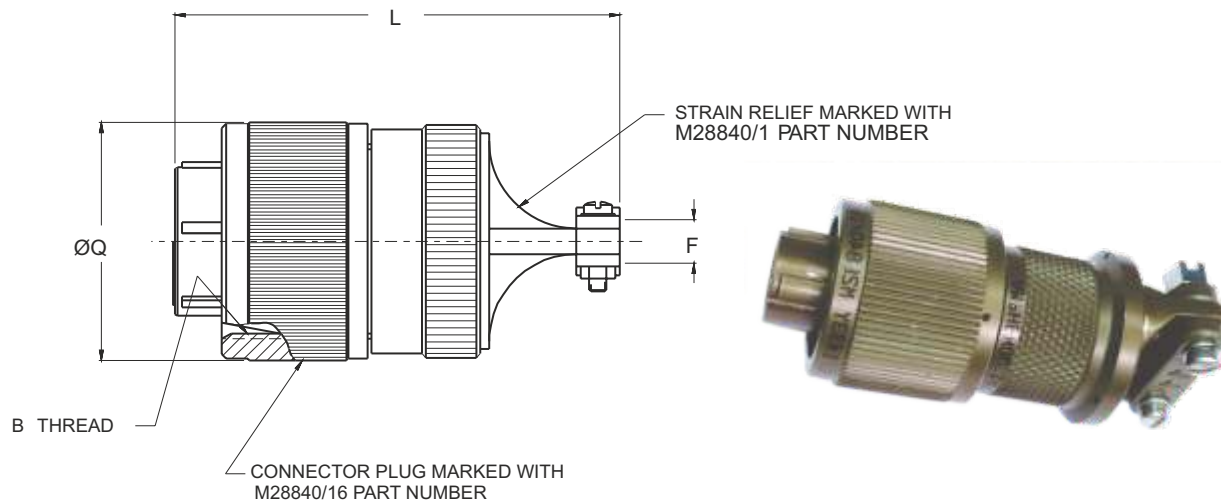
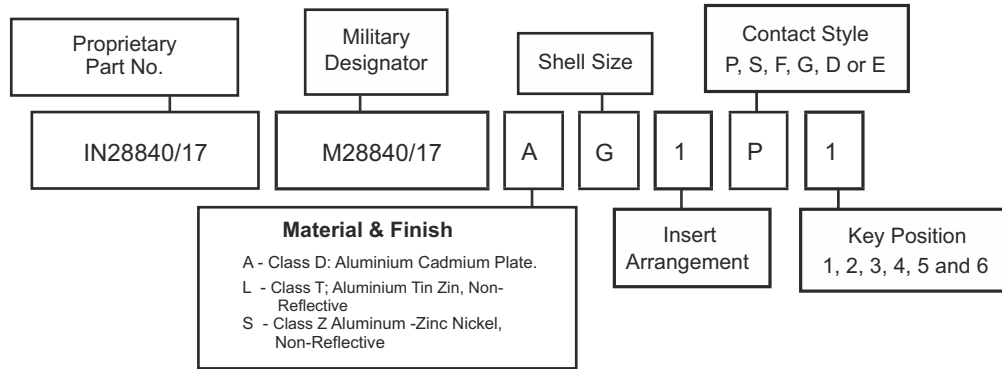

Designator	B Thread Class 2B	F Cable Entry		L Max.	Q Max.	Max. O.D. Over Rear Clamps
		Open	Closed			
A (11)	.750-1P-.2L-DS	7.26 (0.286)	4.50 (.177)	61.92 (2.438)	26.11 (1.028)	21.13 (.832)
B (13)	.875-1P-.2L-DS	7.26 (0.286)			28.98 (1.141)	
C (15)	1.062-1P-.2L-DS	10.57 (.416)	6.35 (.250)		32.08 (1.263)	25.12 (.989)
D (17)	1.125-1P-.2L-DS	12.10 (0.476)	7.39 (.291)	68.27 (2.688)	35.23 (1.387)	27.78 (1.094)
E (19)	1.312-1P-.2L-DS	15.900 (.626)	8.84 (.348)	71.42 (2.812)	38.43 (1.513)	33.50 (1.319)
F (23)	1.500-1P-.2L-DS	21.10 (.831)	10.90 (.429)	74.63 (2.938)	43.25 (1.703)	39.55 (1.557)
G (25)	1.625-1P-.2L-DS	24.28 (.956)	13.28 (.523)	77.78 (3.062)	46.36 (1.825)	41.99 (1.653)
H (29)	1.812-1P-.2L-DS	27.45 (1.081)	16.33 (.643)	80.98 (3.188)	54.43 (2.143)	46.20 (1.819)
J (33)	2.000-1P-.2L-DS	30.15 (1.187)	17.88 (.704)	85.73 (3.375)	59.16 (2.329)	51.31(2.020)

Note: All dimensions are in mm (inches)

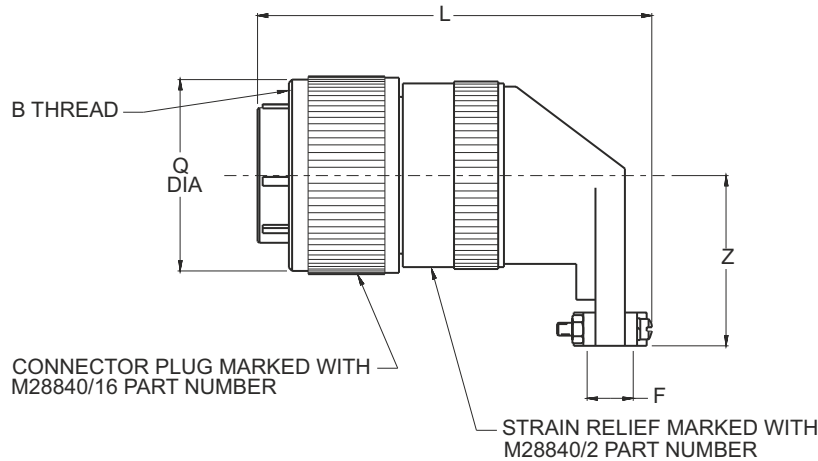
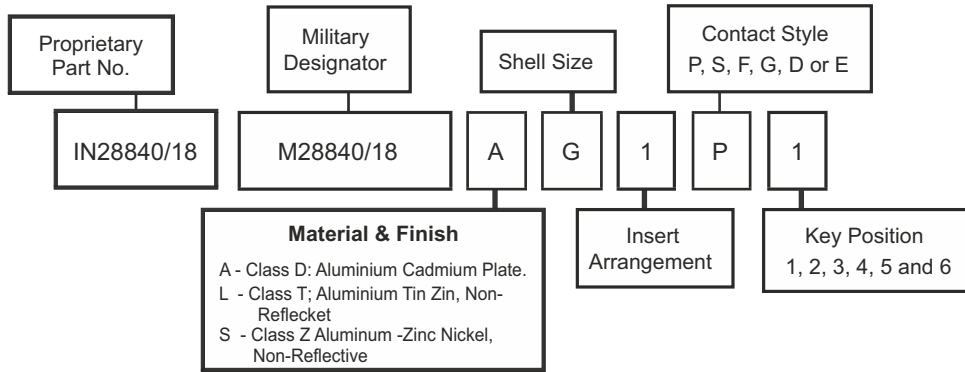

Designator	B Thread Class 2B	F Cable Entry		L Max.	Q Max.	Z Max.	Max. O.D. Over Rear Clamps
		Open	Closed				
A (11)	.750-1P-.2L-DS	(.286) 7.26	(.177) 4.49	(2.562) 65.07	(1.028) 26.11	(.929) 23.60	(.832) 21.13
B (13)	.875-1P-.2L-DS	(.286) 7.26					
C (15)	1.062-1P-.2L-DS	(.416) 10.56	(.250) 6.35	(2.750) 69.85	(1.263) 32.08	(1.056) 26.32	(.989) 25.12
D (17)	1.125-1P-.2L-DS	(.476) 12.09	(.291) 7.39	(2.875) 73.02	(1.387) 35.23	(1.233) 37.32	(1.094) 27.79
E (19)	1.312-1P-.2L-DS	(.626) 15.90	(.348) 8.83	(3.000) 76.2	(1.513) 38.43	(1.296) 32.92	(1.319) 33.50
F (23)	1.500-1P-.2L-DS	(.831) 21.10	(.429) 10.89	(3.125) 79.37	(1.703) 43.25	(1.358) 34.49	(1.557) 39.55
G (25)	1.625-1P-.2L-DS	(.956) 24.28	(.523) 13.28	(3.250) 82.55	(1.825) 46.36	(1.420) 36.07	(1.653) 41.99
H (29)	1.812-1P-.2L-DS	(1.081) 27.45	(.643) 16.33	(3.375) 85.72	(2.143) 54.43	(1.634) 41.50	(1.819) 46.20
J (33)	2.000-1P-.2L-DS	(1.187) 30.14	(.704) 17.88	(3.438) 87.32	(2.329) 59.15	(1.859) 47.22	(2.020) 51.31

Note: All dimensions are in mm (inches)

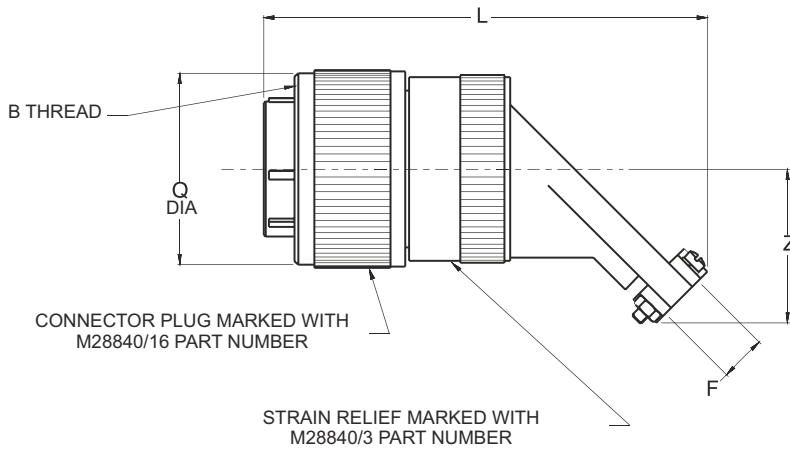
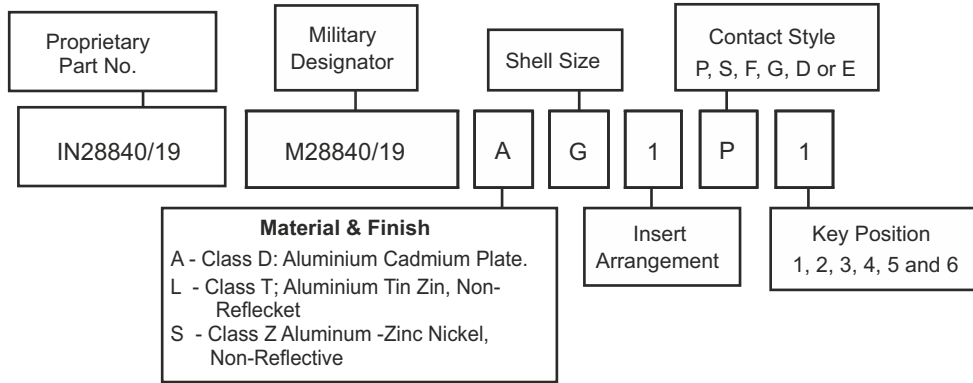

Designator	B Thread Class 2B	F Cable Entry		L Max.	Q Max.	Z Max.	Max. O.D. Over Rear Clamps
		Open	Closed				
A (11)	.750-1P-.2L-DS	(.286) 7.26	(.177) 4.49	(3.125) 79.38	(1.028) 26.11	(.928) 23.57	(.832) 21.13
B (13)	.875-1P-.2L-DS	(.286) 7.26		(3.125) 79.38	(1.141) 28.98	(.928) 23.57	
C (15)	1.062-1P-.2L-DS	(.416) 10.56	(.250) 6.35	(3.250) 82.55	(1.263) 32.08	(.991) 25.17	(.989) 25.12
D (17)	1.125-1P-.2L-DS	(.476) 12.09	(.291) 7.39	(3.312) 84.12	(1.387) 35.22	(1.110) 28.19	(1.046) 26.57
E (19)	1.312-1P-.2L-DS	(.626) 15.90	(.348) 8.83	(3.375) 85.725	(1.513) 38.43	(1.172) 29.76	(1.319) 33.50
F (23)	1.500-1P-.2L-DS	(.831) 21.10	(.429) 10.89	(3.438) 87.32	(1.703) 43.25	(1.235) 31.37	(1.557) 39.54
G (25)	1.625-1P-.2L-DS	(.956) 24.28	(.523) 13.28	(3.500) 88.9	(1.825) 46.35	(1.297) 32.94	(1.653) 41.98
H (29)	1.812-1P-.2L-DS	(1.081) 27.45	(.643) 16.33	(3.750) 95.25	(2.143) 54.43	(1.543) 39.19	(1.819) 46.20
J (33)	2.000-1P-.2L-DS	(1.187) 30.14	(.704) 17.88	(3.875) 98.425	(2.329) 59.15	(1.668) 42.36	(2.020) 51.30

Note: All dimensions are in mm (inches)

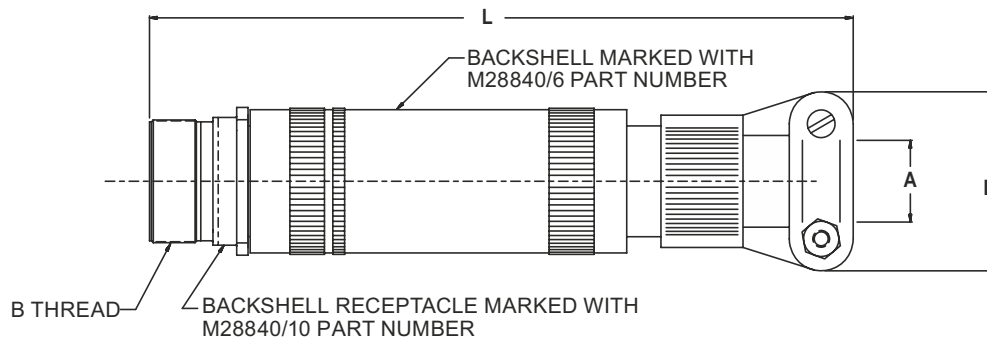
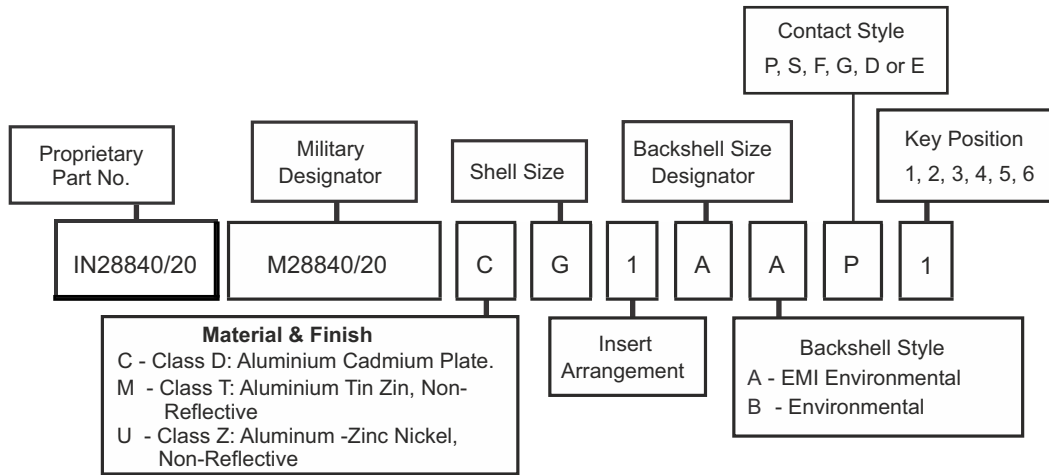

Note: All dimensions are in mm (inches)

Military Shell Size	Shell Size	Backshell Size Designator	A Cable Entry		B Thread Class 2B	E Max.	L Max.
			Open	Closed			
A	11	A	(.312) 7.92	(.188) 4.77	.750-1P-.2L-DS	(.938) 23.82	(6.625) 168.27
A	11	B	(.438) 11.12	(.281) 7.13		(1.125) 28.58	(6.625) 168.27
A	11	C	(.562) 14.27	(.344) 8.73		(1.312) 33.32	(6.625) 168.27
B	13	A	(.312) 7.92	(.188) 4.77	.875-1P-.2L-DS	(.938) 23.82	(6.625) 168.27
B	13	B	(.438) 11.12	(.281) 7.13		(1.125) 28.58	(6.625) 168.27
B	13	C	(.562) 14.27	(.344) 8.79		(1.312) 33.32	(6.625) 168.27
B	13	D	(.625) 15.88	(.375) 9.52		(1.312) 33.32	(7.125) 180.98
C	15	A	(.438) 11.12	(.281) 7.13	1.062-1P-.2L-DS	(1.125) 28.58	(6.625) 168.27
C	15	B	(.562) 14.27	(.344) 8.73		(1.312) 33.32	(6.625) 168.27
C	15	C	(.625) 15.87	(.375) 9.52		(1.312) 33.32	(7.125) 180.97
C	15	D	(.750) 19.05	(.438) 11.12		(1.593) 40.46	(7.188) 182.57
C	15	E	(.312) 7.92	(.188) 4.77		(.938) 23.82	(6.625) 168.27
D	17	A	(.625) 15.88	(.375) 9.52	1.125-1P-.2L-DS	(1.312) 33.32	(7.125) 180.97
D	17	B	(.750) 19.05	(.438) 11.12		(1.593) 40.46	(7.188) 182.57
D	17	C	(.938) 23.82	(.625) 15.87		(1.750) 44.45	(7.188) 182.57
E	19	A	(.625) 15.82	(.375) 9.52	1.312-1P-.2L-DS	(1.312) 33.32	(7.125) 180.97
E	19	B	(.938) 23.82	(.625) 15.87		(1.750) 44.45	(7.250) 184.15
F	23	A	(.750) 19.05	(.438) 11.12	1.500-1P-.2L-DS	(1.593) 40.46	(7.688) 195.27
F	23	B	(.938) 23.82	(.625) 15.87		(1.750) 44.45	(7.812) 198.42
F	23	C	(1.188) 30.17	(.812) 20.62		(2.093) 53.16	(7.938) 201.62
G	25	A	(.938) 23.82	(.625) 15.87	1.625-1P-.2L-DS	(1.750) 44.45	(7.750) 196.85
G	25	B	(1.188) 30.17	(.812) 20.62		(2.093) 53.16	(8.438) 214.32
G	25	C	(1.250) 31.75	(.875) 22.22		(2.093) 53.16	(8.438) 214.32
G	25	D	(1.380) 35.05	(1.000) 25.4		(2.343) 59.51	(8.500) 215.9
H	29	A	(1.188) 30.17	(.812) 20.62	1.812-1P-.2L-DS	(2.093) 53.16	(8.438) 214.32
H	29	B	(1.380) 35.05	(1.000) 25.4		(2.343) 59.51	(8.500) 215.9
J	33	A	(1.380) 35.05	(1.000) 25.4	2.000-1P-.2L-DS	(2.343) 59.51	(8.500) 215.9
J	33	B	(1.625) 41.27	(1.250) 31.75		(2.750) 69.85	(8.750) 222.25

Note: All dimensions are in mm (inches)

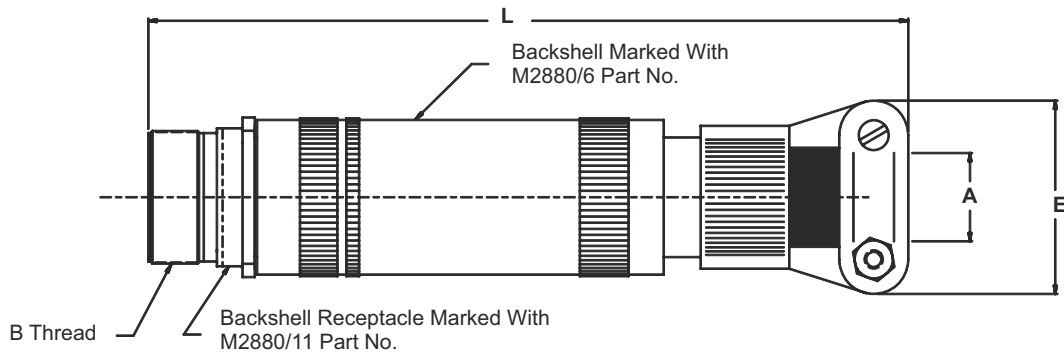
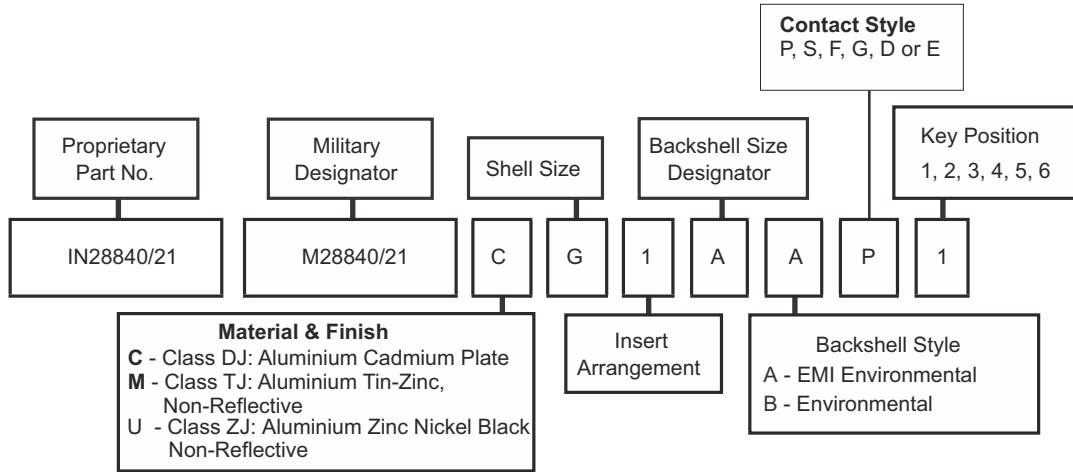

Note: All dimensions are in mm (inches)

Military Shell Size	Shell Size	Backshell Size Designator	A Cable Entry		B Thread Class 2B	E Max.	L Max.
			Open	Closed			
A	11	A	(.312) 7.92	(.188) 4.77	.750-1P-.2L-DS	(.938) 23.82	(6.625) 168.27
A	11	B	(.438) 11.12	(.281) 7.13		(1.125) 28.58	(6.625) 168.27
A	11	C	(.562) 14.27	(.344) 8.73		(1.312) 33.32	(6.625) 168.27
B	13	A	(.312) 7.92	(.188) 4.77	.875-1P-.2L-DS	(.938) 23.82	(6.625) 168.27
B	13	B	(.438) 11.12	(.281) 7.13		(1.125) 28.58	(6.625) 168.27
B	13	C	(.562) 14.27	(.344) 8.79		(1.312) 33.32	(6.625) 168.27
B	13	D	(.625) 15.88	(.375) 9.52		(1.312) 33.32	(7.125) 184.15
C	15	A	(.438) 11.12	(.281) 7.13	1.062-1P-.2L-DS	(1.125) 28.58	(6.625) 168.27
C	15	B	(.562) 14.27	(.344) 8.73		(1.312) 33.32	(6.625) 168.27
C	15	C	(.625) 15.87	(.375) 9.52		(1.312) 33.32	(7.125) 180.97
C	15	D	(.750) 19.05	(.438) 11.12		(1.593) 40.46	(7.188) 182.57
C	15	E	(.312) 7.92	(.188) 4.77		(.938) 23.82	(6.625) 168.27
D	17	A	(.625) 15.88	(.375) 9.52	1.125-1P-.2L-DS	(1.312) 33.32	(7.125) 180.97
D	17	B	(.750) 19.05	(.438) 11.12		(1.593) 40.46	(7.188) 182.57
D	17	C	(.938) 23.82	(.625) 15.87		(1.750) 44.45	(7.188) 182.57
E	19	A	(.625) 15.82	(.375) 9.52	1.312-1P-.2L-DS	(1.312) 33.32	(7.125) 180.97
E	19	B	(.938) 23.82	(.625) 15.87		(1.750) 44.45	(7.250) 184.15
F	23	A	(.750) 19.05	(.438) 11.12	1.500-1P-.2L-DS	(1.593) 40.46	(7.688) 195.27
F	23	B	(.938) 23.82	(.625) 15.87		(1.750) 44.45	(7.812) 198.42
F	23	C	(1.188) 30.17	(.812) 20.62		(2.093) 53.16	(7.938) 201.62
G	25	A	(.938) 23.82	(.625) 15.87	1.625-1P-.2L-DS	(1.750) 44.45	(7.750) 196.85
G	25	B	(1.188) 30.17	(.812) 20.62		(2.093) 53.16	(8.438) 214.32
G	25	C	(1.250) 31.75	(.875) 22.22		(2.093) 53.16	(8.438) 214.32
G	25	D	(1.380) 35.05	(1.000) 25.4		(2.343) 59.51	(8.500) 215.9
H	29	A	(1.188) 30.17	(.812) 20.62	1.812-1P-.2L-DS	(2.093) 53.16	(8.438) 214.32
H	29	B	(1.380) 35.05	(1.000) 25.4		(2.343) 59.51	(8.500) 215.9
J	33	A	(1.380) 35.05	(1.000) 25.4	2.000-1P-.2L-DS	(2.343) 59.51	(8.500) 215.9
J	33	B	(1.625) 41.27	(1.250) 31.75		(2.750) 69.85	(8.750) 222.25

Note: All dimensions are in mm (inches)

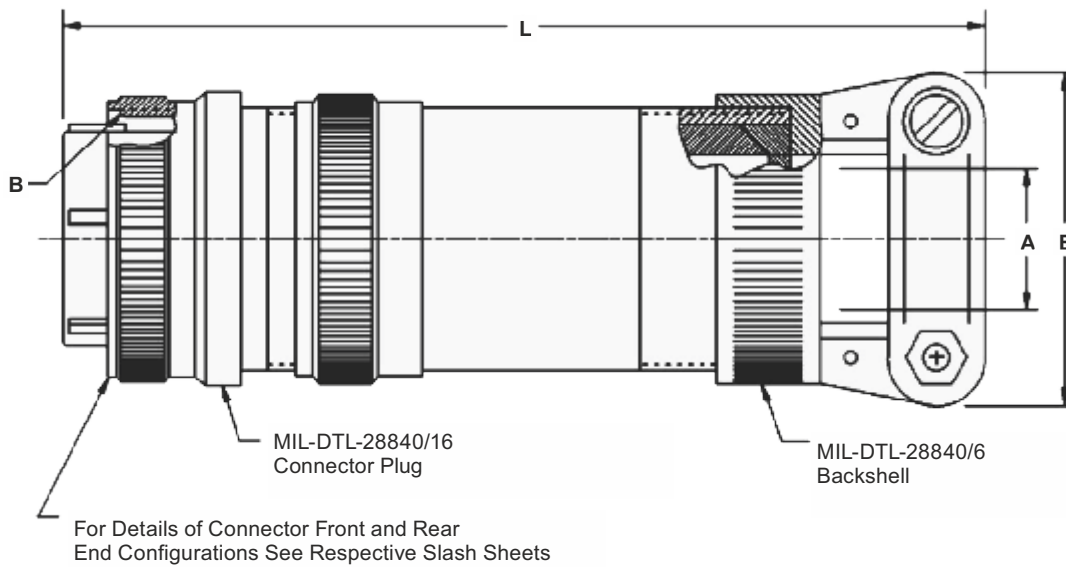
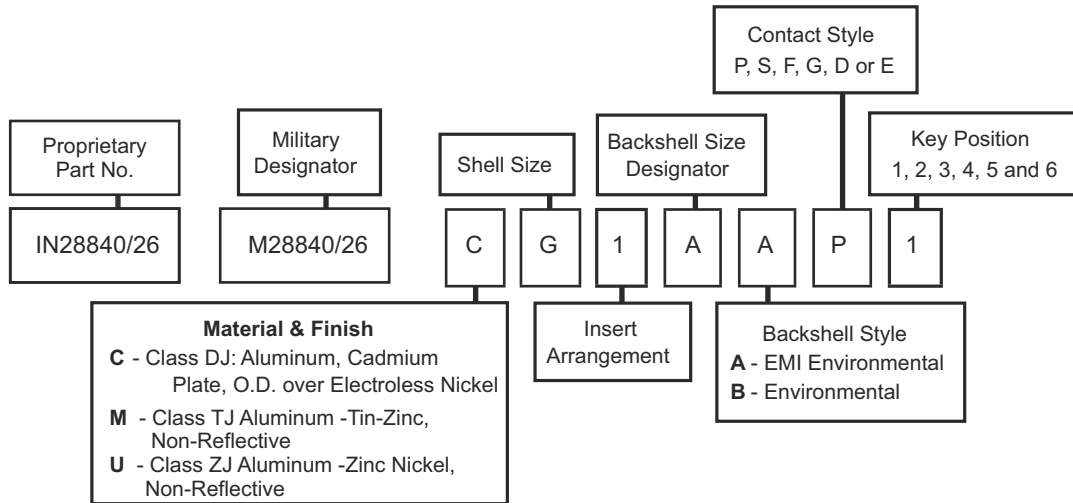

Note: All dimensions are in mm (inches)

Military Shell Size	Shell Size	B Thread Class 2B	Backshell Size Designator	A Cable Entry		E Max.	L Max.
				Open	Closed		
A	11	.750-1P-.2L-DS	A	(.312) 7.92	(.188) 4.77	(.938) 23.82	(6.500) 165.1
			B	(.438) 11.12	(.281) 7.13	(1.175) 28.57	
			C	(.562) 14.27	(.344) 8.73	(1.312) 33.32	
B	13	.875-1P-.2L-DS	A	(.312) 7.92	(.188) 4.77	(.938) 23.82	(7.000) 177.8
			B	(.438) 11.12	(.281) 7.13	(1.125) 28.57	
			C	(.562) 14.27	(.344) 8.73	(1.312) 33.32	
			D	(.652) 16.56	(.375) 9.52	(1.312) 33.32	
C	15	1.062-1P-.2L-DS	A	(.438) 11.12	(.281) 7.13	(1.125) 28.57	(7.000) 177.8
			B	(.562) 14.27	(.347) 8.73	(1.312) 33.32	
			C	(.625) 15.87	(.375) 9.52	(1.312) 33.32	
			D	(.750) 19.05	(.438) 11.12	(1.593) 40.46	
			E	(.312) 7.92	(.188) 4.77	(0.938) 23.82	
D	17	1.125-1P-.2L-DS	A	(.625) 15.87	(.375) 9.52	(1.312) 33.32	(7.0) 177.80
			B	(.750) 19.05	(.438) 11.12	(1.595) 40.46	
			C	(.938) 23.82	(.625) 15.87	(1.750) 44.45	
E	19	1.312-1P-.2L-DS	A	(.625) 15.87	(.375) 9.52	(1.312) 33.32	(7.0) 177.80
			B	(.938) 23.82	(.625) 15.87	(1.175) 44.15	(7.0) 177.80
F	23	1.500-1P-.2L-DS	A	(.750) 19.05	(.438) 11.12	(1.593) 40.46	(7.5) 190.50
			B	(.938) 23.82	(.625) 15.87	(1.750) 44.45	(7.625) 193.67
			C	(1.188) 30.17	(.812) 20.62	(2.093) 53.16	(7.812) 198.42
G	25	1.625-1P-.2L-DS	A	(.938) 23.82	(.625) 15.87	(1.750) 44.45	(8.312) 211.12
			B	(1.188) 30.17	(.812) 20.62	(2.093) 53.16	
			C	(1.250) 31.75	(.875) 22.22	(2.093) 53.16	
			D	(1.380) 35.05	(1.00) 25.4	(2.343) 59.51	
H	29	1.812-1P-.2L-DS	A	(1.188) 30.17	(.812) 20.62	(2.093) 53.16	(8.625) 219.8
			B	(1.380) 35.05	(1.00) 25.4	(2.343) 59.51	
J	33	2.000-1P-.2L-DS	A	(1.380) 35.05	(1.00) 25.4	(2.343) 59.51	(8.625) 219.8
			B	(1.625) 41.27	(1.256) 31.75	(2.750) 69.85	

Note: All dimensions are in mm (inches)

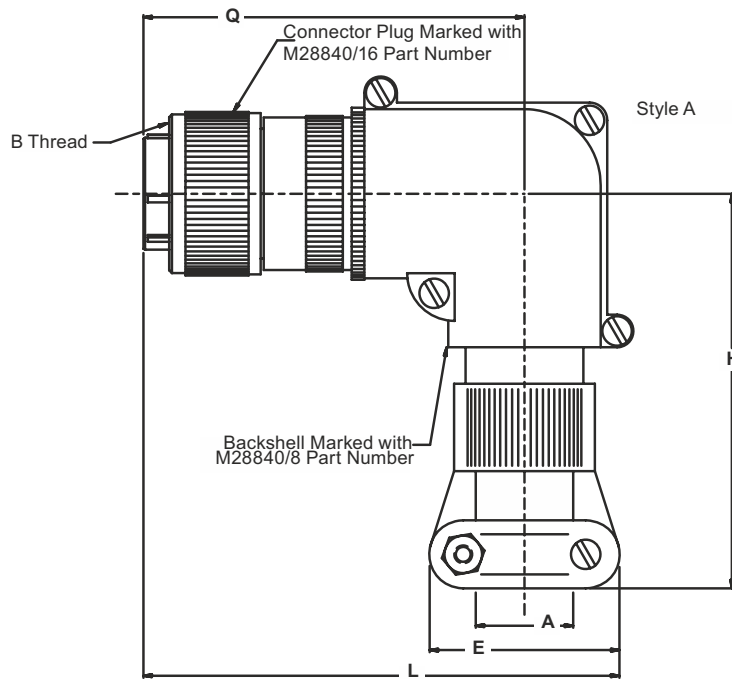
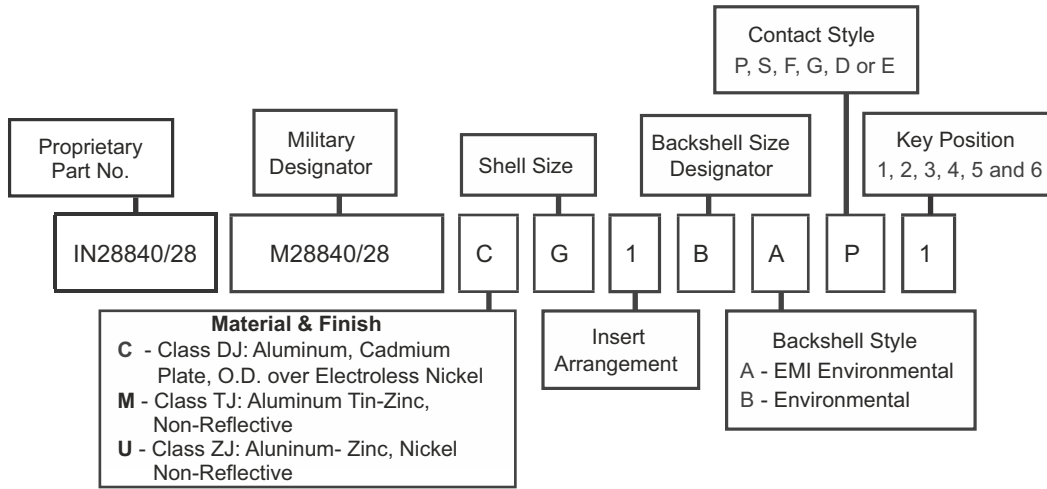

Note: All dimensions are in mm (inches)

Military Shell Size	Shell Size	Backshell Size Designator	A Cable Entry		B Thread Class 2B	E Ref.	H Max.	L Max.	Q Max.
			Open	Closed					
A	11	A	(.312) 7.92	(.188) 4.77	.750-1P-.2L-DS	(.938) 23.82	(5.332) 135.43	(3.812) 96.82	(3.306) 82.55
A	11	B	(.438) 11.12	(.281) 7.13		(1.125) 28.57	(5.332) 135.43	(3.812) 96.82	(3.306) 82.55
A	11	C	(.562) 14.27	(.344) 8.73		(1.312) 33.32	(5.457) 138.60	(4.000) 101.6	(3.375) 85.72
B	13	A	(.312) 7.92	(.188) 4.77	.875-1P-.2L-DS	(.938) 23.82	(5.332) 135.43	(3.812) 96.82	(3.250) 82.55
B	13	B	(.438) 11.13	(.281) 7.13		(1.125) 28.57	(5.332) 135.43	(4.000) 101.6	(3.375) 82.72
B	13	C	(.562) 14.27	(.344) 8.73		(1.312) 33.32	(5.457) 138.60	(4.250) 107.95	(3.500) 88.9
C	15	A	(.438) 11.13	(.281) 7.13	1.062-1P-.2L-DS	(1.125) 28.57	(5.457) 138.60	(4.000) 101.6	(3.375) 85.72
C	15	B	(.562) 14.27	(.344) 8.73		(1.312) 33.32	(5.457) 138.60	(4.000) 101.6	(3.375) 85.72
C	15	C	(.625) 15.87	(.375) 9.52		(1.312) 33.32	(5.682) 114.32	(4.250) 107.95	(3.500) 98.9
C	15	D	(.750) 19.05	(.438) 11.12		(1.593) 40.46	(5.713) 145.11	(4.150) 104.77	(3.500) 88.9
D	17	A	(.625) 16.56	(.375) 9.52	1.125-1P-.2L-DS	(1.312) 33.32	(5.682) 144.32	(4.250) 107.95	(3.500) 88.9
D	17	B	(.750) 19.05	(.438) 11.12		(1.593) 40.46	(5.713) 145.11	(4.250) 107.95	(3.500) 88.9
E	19	A	(.625) 15.87	(.375) 9.52	1.312-1P-.2L-DS	(1.312) 33.32	(5.682) 144.32	(4.250) 107.95	(3.500) 88.9
E	19	B	(.938) 23.82	(.625) 15.87		(1.750) 44.45	(5.832) 148.13	(4.375) 111.12	(3.625) 92.07
F	23	A	(.750) 19.05	(.438) 11.12	1.500-1P-.2L-DS	(1.593) 40.46	(5.738) 145.74	(4.500) 114.3	(3.625) 92.07
F	23	B	(.938) 23.82	(.625) 15.87		(1.750) 44.45	(5.832) 148.13	(4.500) 114.3	(3.625) 92.07
F	23	C	(1.188) 30.17	(.812) 20.62		(2.093) 53.16	(6.019) 152.88	(4.688) 119.07	(3.625) 92.07
G	25	A	(.938) 23.82	(.625) 15.87	1.625-1P-.2L-DS	(1.750) 44.45	(5.832) 148.13	(4.500) 114.3	(3.625) 92.07
G	25	B	(1.188) 30.17	(.812) 20.62		(2.093) 53.16	(6.019) 152.88	(4.688) 119.07	(3.625) 92.07
G	25	C	(1.250) 31.75	(.875) 22.22		(2.093) 53.16	(6.144) 156.05	(4.688) 119.07	(3.750) 95.25
G	25	D	(1.380) 35.05	(1.000) 25.4		(2.343) 59.51	(6.176) 156.87	(4.938) 125.42	(3.750) 95.25
H	29	A	(1.188) 30.17	(.812) 20.62	1.812-1P-.2L-DS	(2.093) 53.16	(6.144) 156.05	(4.812) 122.22	(3.750) 95.25
H	29	B	(1.380) 35.05	(1.000) 25.4		(2.343) 59.51	(6.176) 156.87	(4.938) 125.42	(3.750) 95.25
J	33	A	(1.380) 35.05	(1.000) 25.4	2.000-1P-.2L-DS	(2.343) 59.51	(6.426) 163.22	(5.188) 131.77	(4.000) 101.6
J	33	B	(1.625) 41.27	(1.250) 31.75		(2.750) 69.85	(6.701) 170.20	(5.375) 136.52	(4.000) 101.6

Note: All dimensions are in mm (inches)

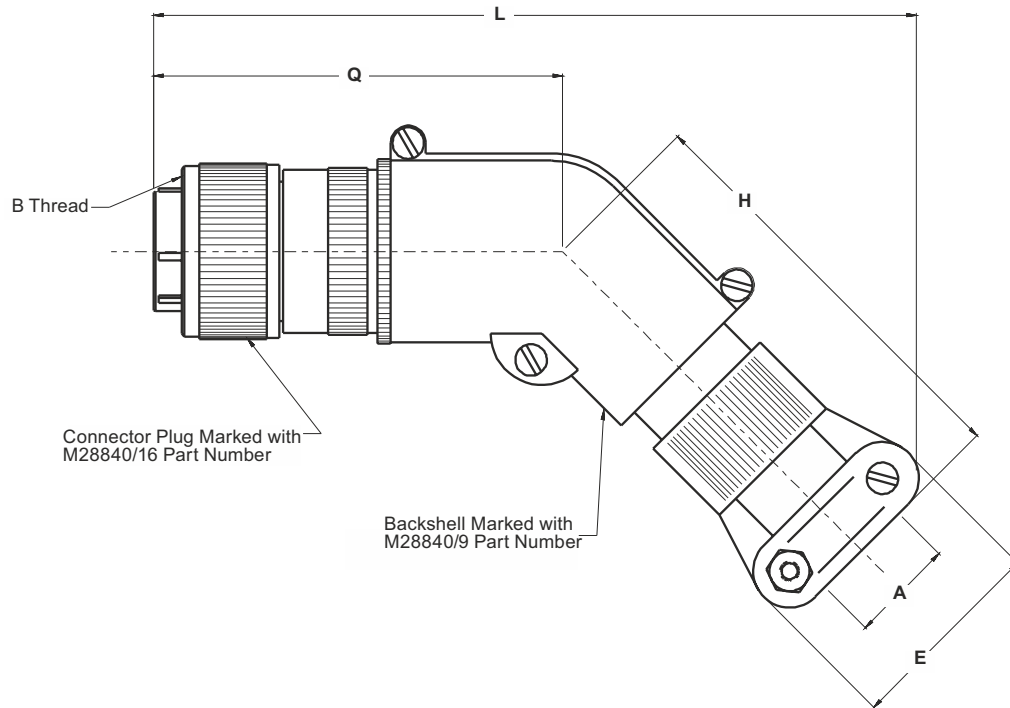
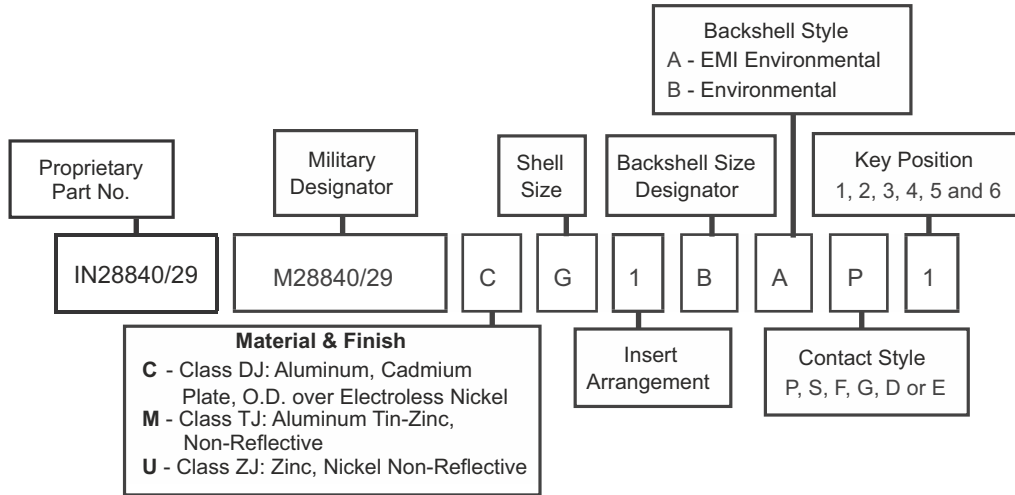

Note: All dimensions are in mm (inches)

Military Shell Size	Shell Size	Backshell Size Designator	A Cable Entry		B Thread Class 2B	E Ref.	H Max.	L Max.	Q Max.
			Open	Closed					
A	11	A	(.312) 7.92	(.188) 4.77	.750-1P-.2L-DS	(.938) 23.82	(5.432) 137.97	(7.404) 188.06	(3.250) 82.55
A	11	B	(.438) 11.12	(.281) 7.13		(1.125) 28.57	(5.432) 137.97	(7.457) 188.40	(3.250) 82.55
A	11	C	(.562) 14.27	(.344) 8.73		(1.312) 33.32	(5.557) 141.14	(7.727) 196.26	(3.375) 85.72
B	13	A	(.312) 7.92	(.188) 4.77	.875-1P-.2L-DS	(.938) 23.82	(5.432) 137.97	(7.457) 189.40	(3.250) 82.55
B	13	B	(.438) 11.12	(.281) 7.13		(1.125) 28.57	(5.432) 137.97	(7.727) 196.26	(3.375) 85.72
B	13	C	(.562) 14.27	(.344) 8.73		(1.312) 33.32	(5.557) 141.14	(7.938) 201.62	(3.500) 88.9
C	15	A	(.438) 11.12	(.281) 7.13	1.062-1P-.2L-DS	(1.125) 28.57	(5.557) 141.14	(7.671) 194.84	(3.375) 85.72
C	15	B	(.562) 14.27	(.344) 8.73		(1.312) 33.32	(5.557) 141.14	(7.727) 196.26	(3.375) 85.72
C	15	C	(.625) 15.87	(.375) 9.52		(1.312) 33.32	(5.682) 144.32	(7.938) 201.62	(3.500) 88.9
C	15	D	(.750) 19.05	(.438) 11.12	1.125-1P-.2L-DS	(1.593) 40.46	(5.713) 145.11	(8.058) 204.67	(3.500) 88.9
D	17	A	(.625) 15.87	(.375) 9.52		(1.312) 33.32	(5.682) 144.32	(7.938) 201.62	(3.500) 88.9
D	17	B	(.750) 19.05	(.438) 11.12		(1.593) 40.46	(5.713) 145.11	(8.058) 204.67	(3.500) 88.9
E	19	A	(.625) 15.87	(.375) 9.52	1.312-1P-.2L-DS	(1.312) 33.32	(5.682) 144.32	(7.938) 201.62	(3.500) 88.9
E	19	B	(.938) 23.82	(.625) 15.87		(1.750) 44.45	(5.932) 150.67	(8.371) 212.62	(3.625) 92.07
F	23	A	(.750) 19.05	(.438) 11.12	1.500-1P-.2L-DS	(1.593) 40.46	(5.838) 148.28	(8.272) 210.10	(3.625) 92.07
F	23	B	(.938) 23.82	(.625) 15.87		(1.750) 44.45	(5.932) 150.67	(8.371) 212.62	(3.625) 92.07
F	23	C	(1.188) 30.17	(.812) 20.62		(2.093) 53.16	(6.119) 155.42	(8.628) 219.15	(3.625) 92.07
G	25	A	(.938) 23.82	(.625) 15.87	1.625-1P-.2L-DS	(1.750) 44.45	(5.932) 150.67	(8.371) 212.62	(3.625) 92.07
G	25	B	(1.188) 30.17	(.812) 20.62		(2.093) 53.16	(6.119) 155.42	(8.628) 219.15	(3.625) 92.07
G	25	C	(1.250) 31.75	(.875) 22.22		(2.093) 53.16	(6.244) 158.59	(8.841) 224.56	(3.750) 95.25
G	25	D	(1.380) 35.05	(1.000) 25.4		(2.343) 59.51	(6.276) 159.41	(8.950) 227.33	(3.750) 95.25
H	29	A	(1.188) 30.17	(.812) 20.62	1.812-1P-.2L-DS	(2.093) 53.16	(6.244) 158.59	(8.841) 224.56	(3.750) 95.25
H	29	B	(1.380) 35.05	(1.000) 25.4		(2.343) 59.51	(6.276) 159.41	(8.950) 227.33	(3.750) 95.25
J	33	A	(1.380) 35.05	(1.000) 25.4	2.000-1P-.2L-DS	(2.343) 59.51	(6.526) 165.76	(9.377) 238.17	(4.000) 101.6
J	33	B	(1.625) 41.27	(1.250) 31.75		(2.750) 69.85	(6.801) 172.74	(9.659) 245.33	(4.000) 101.6

Note: All dimensions are in mm (inches).

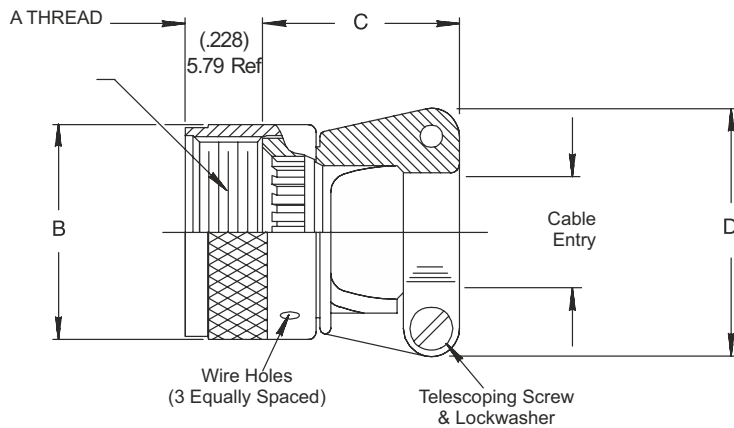
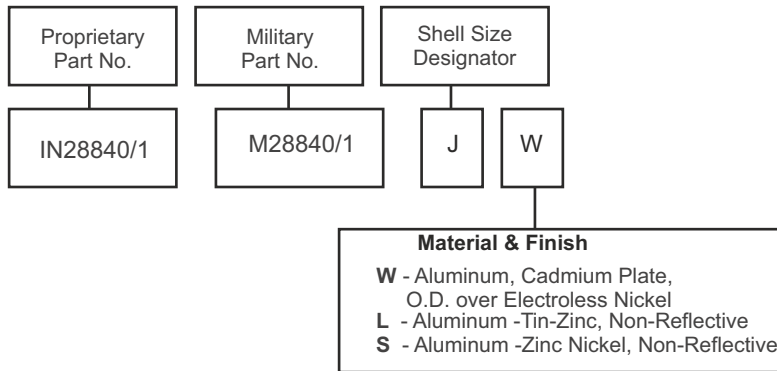

Designator	A Thread Class 2B	B Max. Diameter	C Max.	D Max.	Screw Size Ref.	Cable Entry	
						Min.	Max.
A (11)	.750-20 UNEF	(1.028) 26.11	(1.091) 27.71	(.903) 22.94	.114-40	(.177) 4.50	(.286) 7.26
B (13)	.875-20 UNEF	(1.141) 28.98	(1.091) 27.71	(.977) 24.82	.114-40	(.177) 4.50	(.286) 7.26
C (15)	1.000-20 UNEF	(1.263) 32.08	(1.091) 27.71	(1.151) 29.24	.114-40	(.250) 6.35	(.416) 10.57
D (17)	1.125-18 UNEF	(1.387) 35.23	(1.206) 30.63	(1.281) 32.54	.114-40	(.291) 7.39	(.476) 12.09
E (19)	1.250-18 UNEF	(1.513) 38.43	(1.320) 33.53	(1.406) 35.71	.114-40	(.348) 8.84	(.626) 15.90
F (23)	1.438-18 UNEF	(1.703) 43.26	(1.445) 36.70	(1.576) 40.03	.134-32	(.429) 10.90	(.831) 21.11
G (25)	1.562-18 UNEF	(1.825) 46.36	(1.570) 39.88	(1.666) 42.32	.134-32	(.523) 13.28	(.956) 24.28
H (29)	1.875-16 UN	(2.143) 54.43	(1.721) 43.71	(2.046) 51.97	.134-32	(.643) 16.33	(1.081) 27.46
J (33)	2.062-16 UNS	(2.329) 59.16	(1.908) 48.46	(2.209) 56.11	.162-32	(.704) 17.88	(1.187) 30.15

Note: All Dimensions for reference only.
All dimensions are in mm (inches)

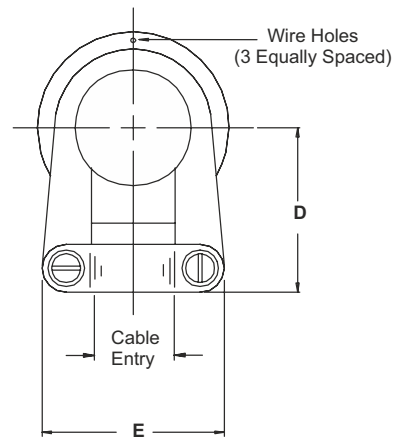
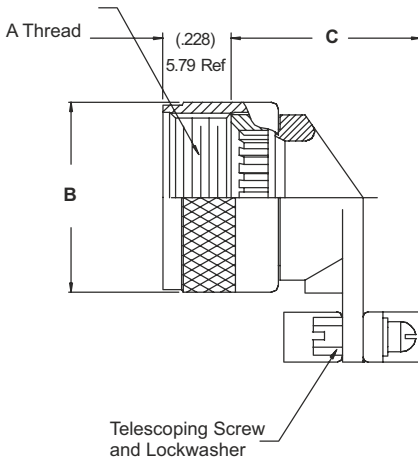
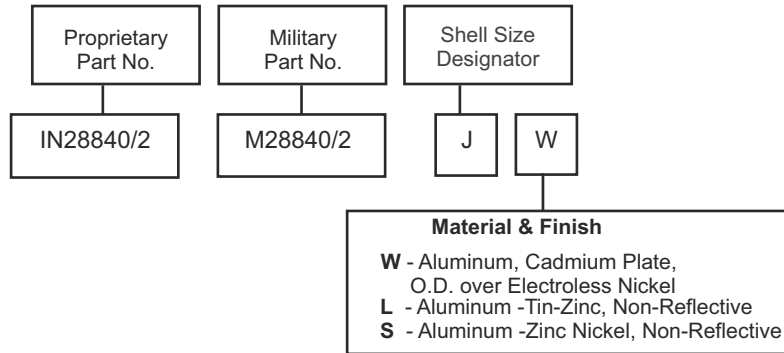

Designator	A Thread Class 2B	B Max. Diameter	C Max.	D Max.	E Max.	Screw Size Ref.	Cable Entry	
							Min.	Max.
A (11)	.750-20 UNEF	(1.028) 26.11	(1.071) 27.20	(.929) 23.60	(.903) 22.94	.114-40	(.177) 4.50	(.286) 7.26
B (13)	.875-20 UNEF	(1.141) 28.98	(1.071) 27.20	(.929) 23.60	(.977) 24.82	.114-40	(.177) 4.50	(.286) 7.26
C (15)	1.000-20 UNEF	(1.263) 32.08	(1.280) 32.51	(1.056) 26.82	(1.151) 29.24	.114-40	(.250) 6.35	(.416) 10.57
D (17)	1.125-18 UNEF	(1.387) 35.23	(1.392) 35.36	(1.233) 31.32	(1.281) 32.54	.114-40	(.291) 7.39	(.476) 12.09
E (19)	1.250-18 UNEF	(1.513) 38.43	(1.517) 38.53	(1.296) 32.92	(1.406) 35.71	.114-40	(.348) 8.84	(.626) 15.90
F (23)	1.438-18 UNEF	(1.703) 43.26	(1.642) 41.71	(1.358) 34.49	(1.576) 40.03	.134-32	(.429) 10.90	(.831) 21.11
G (25)	1.562-18 UNEF	(1.825) 46.36	(1.767) 44.88	(1.420) 36.07	(1.666) 42.32	.134-32	(.523) 13.28	(.956) 24.28
H (29)	1.875-16 UN	(2.143) 54.43	(1.905) 48.39	(1.634) 41.50	(2.046) 51.97	.134-32	(.643) 16.33	(1.081) 27.46
J (33)	2.062-16 UNS	(2.329) 59.16	(1.968) 49.99	(1.859) 47.22	(2.209) 56.11	.162-32	(.704) 17.88	(1.187) 30.15

Note: All dimensions are in mm (inches)

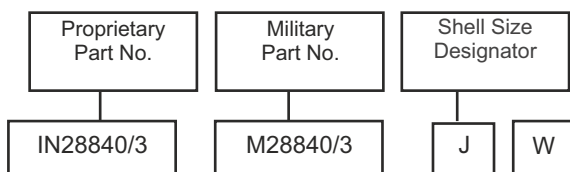

Material & Finish
W - Aluminum, Cadmium Plate, O.D. over Electroless Nickel
L - Aluminum -Tin-Zinc, Non-Reflective
S - Aluminum -Zinc Nickel, Non-Reflective

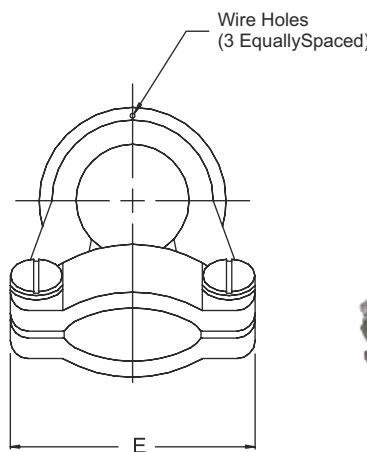
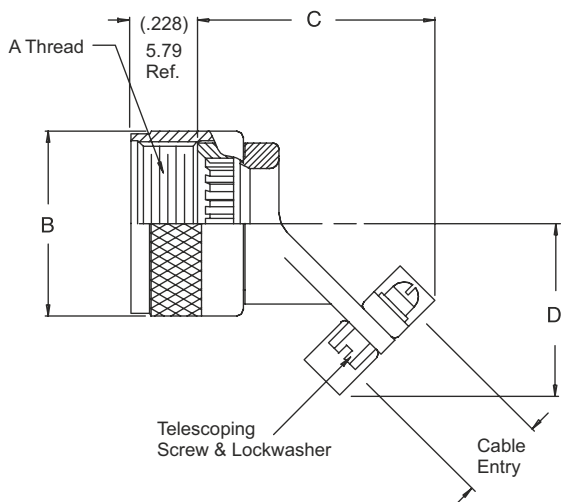

Designator	A Thread Class 2B	B Max. Diameter	C Max.	D Max.	E Max.	Screw Size Ref.	Cable Entry	
							Min.	Max.
A (11)	.750-20 UNEF	(1.028) 26.11	(1.650) 23.60	(.929) 23.60	(.903) 22.94	.114-40	(.177) 4.50	(.286) 7.26
B (13)	.875-20 UNEF	(1.141) 28.98	(1.650) 23.60	(.929) 23.60	(.977) 24.82	.114-40	(.177) 4.50	(.286) 7.26
C (15)	1.000-20 UNEF	(1.263) 32.08	(1.745) 44.6	(1.056) 26.82	(1.151) 29.24	.114-40	(.250) 6.35	(.416) 10.57
D (17)	1.125-18 UNEF	(1.387) 35.23	(1.874) 47.60	(1.233) 31.32	(1.281) 32.54	.114-40	(.291) 7.39	(.476) 12.09
E (19)	1.250-18 UNEF	(1.513) 38.43	(1.918) 48.72	(1.296) 32.92	(1.406) 35.71	.114-40	(.348) 8.84	(.626) 15.90
F (23)	1.438-18 UNEF	(1.703) 43.26	(1.962) 49.83	(1.358) 34.49	(1.576) 40.03	.134-32	(.429) 10.90	(.831) 21.11
G (25)	1.562-18 UNEF	(1.825) 46.36	(2.006) 50.95	(1.420) 36.07	(1.666) 42.32	.134-32	(.523) 13.28	(.956) 24.28
H (29)	1.875-16 UN	(2.143) 54.43	(2.301) 58.45	(1.634) 41.50	(2.046) 51.97	.134-32	(.643) 16.33	(1.081) 27.46
J (33)	2.062-16 UNS	(2.329) 59.16	(2.389) 60.68	(1.859) 47.22	(2.209) 56.11	.162-32	(.704) 17.88	(1.187) 30.15

Note: All dimensions are in mm (inches)

EMI Backshell

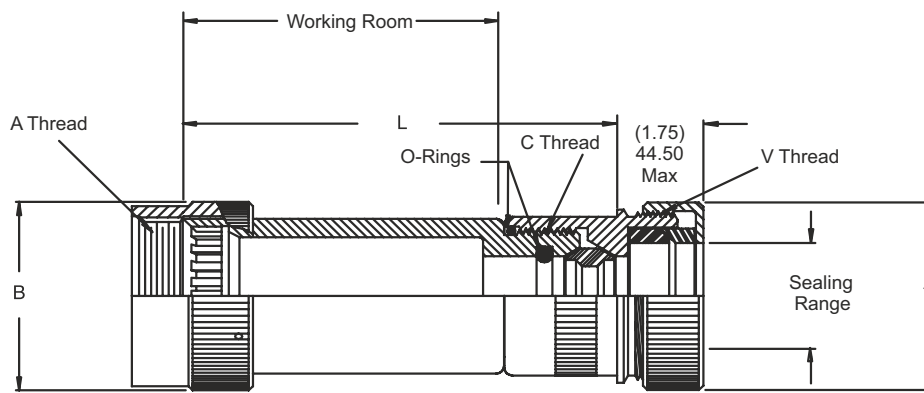
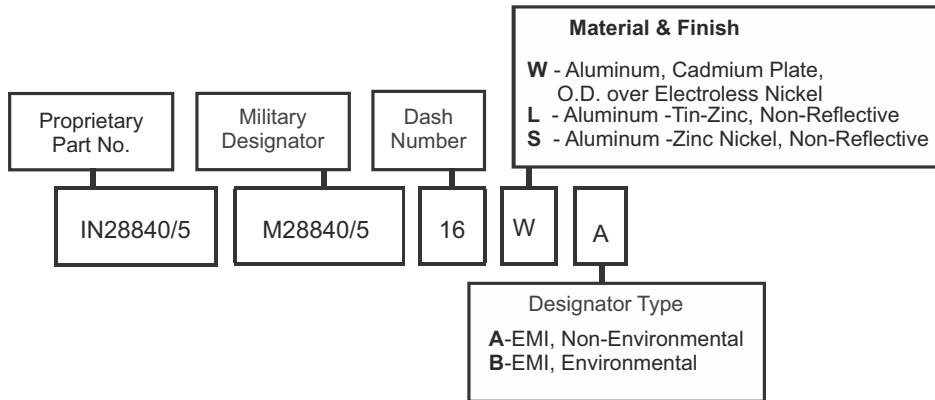

Style B- EMI/Non-Environmental
(Jacket Conduit)

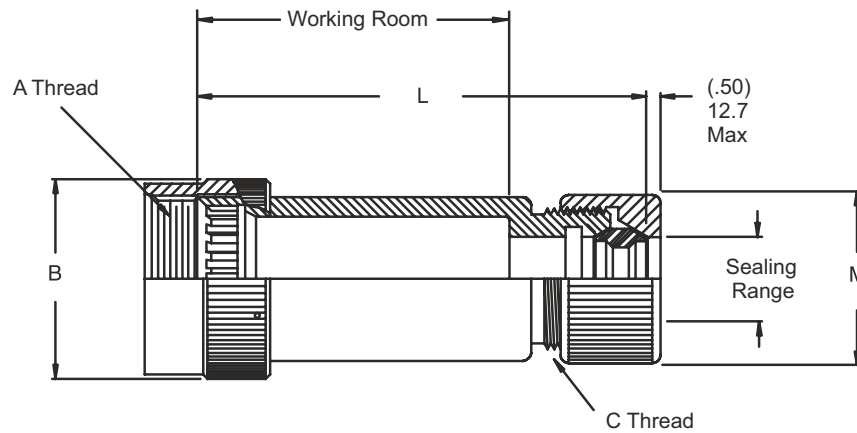

Style A- EMI/Non-Environmental
(Plain Conduit)



Note: All dimensions are in mm (inches)

Dash Number	Designator	Conduit Size	L ± .12 (± 3.05)	Working Room Ref.	V Thread Class 2*	M Max. Diameter	Y Max. Diameter
01	A (11)	03	(1.75) 44.45	(1.00) 25.4	1.00-20 UNEF	(1.12) 28.45	1.19 (30.23)
02	B (13)						
03		04			1.188-18 UNEF	(1.25) 31.8	(1.38) 35.1
04	C (15)	03			1.000-20 UNEF	(1.12) 28.5	(1.19) 30.23
05		04			1.188-30 UNEF	(1.25) 31.8	(1.38) 35.1
06		05			1.438-18 UNEF	(1.43) 36.3	(1.63) 41.4
07		06	(3.00) 76.2	1.750-18 UNS	(1.62) 41.2	(1.94) 49.3	
08	D (17)	05	(2.25) 57.15	(1.50) 38.10	1.438-18 UNEF	(1.43) 36.3	(1.63) 41.4
09		06			1.750-18 UNS	(1.62) 41.2	(1.94) 49.3
10		08		(2.00) 50.80	2.00-18 UNS	(1.81) 46.0	(2.19) 55.6
11	E (19)	05		(1.50) 38.10	1.438-18 UNEF	(1.43) 36.3	(1.63) 41.4
12		06			1.750-18 UNEF	(1.62) 41.2	(1.94) 49.3
13		08			2.00-18 UNS	(1.81) 46.2	(2.19) 55.6
14	F (23)	06	(2.75) 69.85	(2.00) 50.80	1.750-18 UNS	(1.62) 41.2	(1.94) 49.3
15		08			2.00-18 UN	(1.81) 46.0	(2.19) 55.6
16		10			(3.50) 88.90	2.00-16 UN	(2.18) 55.4
17	G (25)	06	(2.75) 69.85		1.750-18 UN	(1.62) 41.2	(1.94) 49.3
18		08			2.00-18 UN	(1.81) 46.0	(2.19) 55.6
19		10			2.250-16 UN	(2.18) 55.4	(2.44) 62.0
20	H (29)	12	(4.00) 101.6	(2.50) 63.50	2.500-16 UN	(2.56) 65.0	(2.69) 68.3
21		10	(3.25) 82.55		2.250-16 UN	(2.18) 55.4	(2.44) 62.0
22		12			2.500-16 UN	(2.56) 65.0	(2.69) 68.3
23		J (33)			12	2.500-16 UN	(2.56) 65.0
24	16			3.00-16 UN	(3.06) 77.8	(3.18) 81.0	
25	A (11)	04	(1.75) 44.45	(1.00) 25.4	1.188-18 UNEF	(1.75) 31.75	(1.38) 35.0

Note: All dimensions are in mm (inches)

Dash No.	Designator	A Thread Class 2B	B Dia. Max.	C Thread Class 2	Sealing Range	
					Max.	Min.
01	A (11)	.750-20 UNEF	(1.028) 26.11	.875-20 UNEF	(.63) 16.0	(0.50) 12.7
02	B (13)	.875-20 UNEF	(1.141) 28.98			
03				1.000-20 UNEF	(.75) 19.1	(.63) 16.0
04	C (15)	1.000-20 UNEF	(1.263) 32.08	.875-20 UNEF	(.63) 16.0	(.50) 12.7
05				1.000-20 UNEF	(.75) 19.1	(.63) 16.0
06				1.125-18 UNEF	(.88) 22.4	(.75) 19.1
07				1.250-18 UNEF	(1.00) 25.4	(.88) 22.4
08	D (17)	1.125-18 UNEF	(1.387) 35.23	1.125-18 UNEF	(.88) 22.4	(.75) 19.1
09				1.250-18 UNEF	(1.00) 25.4	(.88) 22.4
10				1.625-18 UNEF	(1.38) 35.1	(1.19) 30.2
11	E (19)	1.250-18 UNEF	(1.513) 38.43	1.125-18 UNEF	(.88) 22.4	(.75) 19.1
12				1.250-18 UNEF	(1.00) 25.4	(.88) 22.4
13				1.625-18 UNEF	(1.38) 35.1	(1.19) 30.2
14	F (23)	1.438-18 UNEF	(1.703) 43.25	1.250-18 UNEF	(1.00) 25.4	(.88) 22.4
15				1.625-18 UNEF	(1.38) 35.1	(1.19) 30.2
16				1.875-18 UNS	(1.63) 41.4	(1.44) 36.6
17	G (25)	1.562-18 UNEF	(1.825) 46.35	1.250-18 UNEF	(1.00) 25.4	(.88) 22.4
18				1.625-18 UNEF	(1.38) 35.1	(1.19) 30.2
19				1.875-18 UNS	(1.63) 41.4	(1.44) 36.6
20				2.125-16 UN	(1.88) 47.8	(1.63) 41.4
21	H (29)	1.875-16 UN	(2.143) 54.43	1.875-18 UNS	(1.63) 41.4	(1.44) 36.6
22				2.125-16 UN	(1.88) 47.8	(1.63) 41.4
23	J (33)	2.062-16 UNS	(2.329) 59.16	2.125-16 UN	(1.88) 47.8	(1.63) 41.4
24				2.750-16 UN	(2.38) 60.5	(2.13) 54.1
25	A (11)	.750-20 UNEF	(1.028) 26.11	.875-20 UN	(.75) 19.05	(.63) 16.00

Note: All dimensions are in mm (inches)

Cable Sealing Backshell

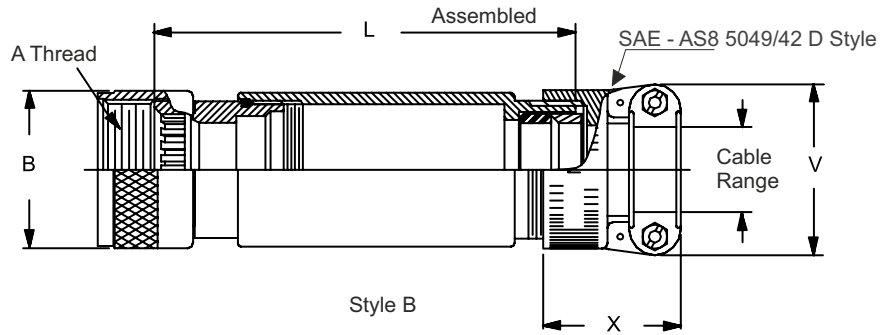
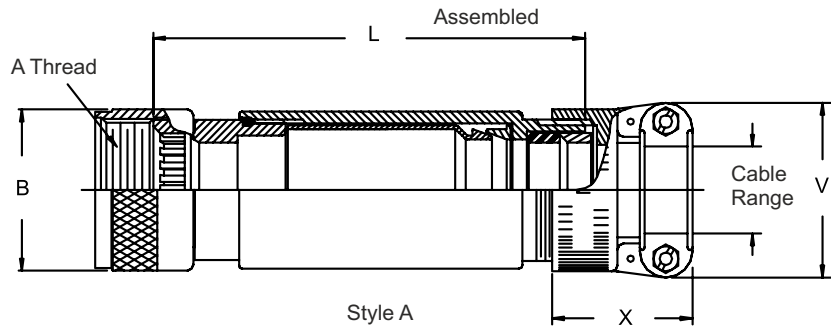
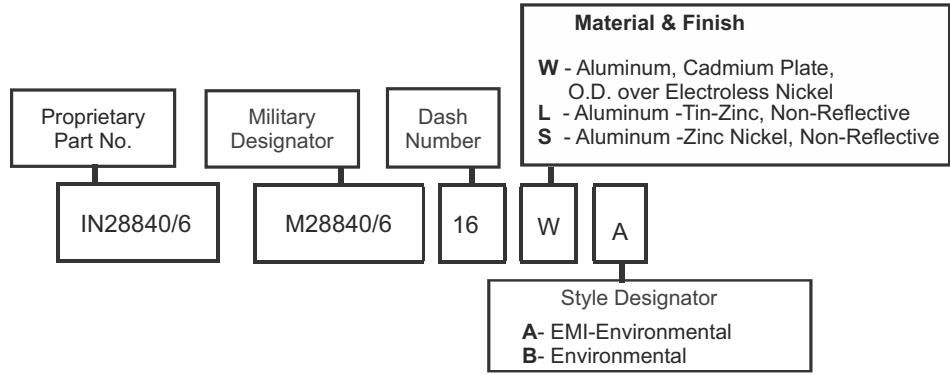

Note: All dimensions are in mm (inches)

Dash Number	Designator	A Thread Class 2B	B Diameter Max.	Cable Range	
				Max.	Min.
01	A (11)	.750-20 UNEF	(1.028) 26.11	(.312) 7.92	(.188) 4.77
02	B (13)	.875-20 UNEF	(1.141) 28.98	(.312) 7.92	(.188) 4.77
03	B (13)	.875-20 UNEF	(1.141) 28.98	(.438) 11.12	(.281) 7.14
04	C (15)	1.000-20 UNEF	(1.263) 32.08	(.312) 7.92	(.188) 4.77
05	C (15)	1.000-20 UNEF	(1.263) 32.08	(.438) 11.12	(.281) 7.14
06	C (15)	1.000-20 UNEF	(1.263) 32.08	(.562) 14.27	(.344) 8.74
07	C (15)	1.000-20 UNEF	(1.263) 32.08	(.750) 19.05	(.438) 11.12
08	D (17)	1.125-18 UNEF	(1.387) 35.23	(.625) 15.87	(.375) 9.52
09	D (17)	1.125-18 UNEF	(1.387) 35.23	(.750) 19.05	(.438) 11.12
10	D (17)	1.125-18 UNEF	(1.387) 35.23	(.938) 23.82	(.625) 15.87
11	E (19)	1.250-18 UNEF	(1.513) 38.43	(.625) 15.87	(.375) 9.52
12	E (19)	1.250-18 UNEF	(1.513) 38.43	(.938) 23.82	(.625) 15.87
13	F (23)	1.438-18 UNEF	(1.703) 43.26	(.750) 19.05	(.438) 11.12
14	F (23)	1.438-18 UNEF	(1.703) 43.26	(.938) 23.82	(.625) 15.87
15	F (23)	1.438-18 UNEF	(1.703) 43.26	(1.188) 30.17	(.812) 20.62
16	G (25)	1.562-18 UNEF	(1.825) 46.35	(.938) 23.82	(.625) 15.87
17	G (25)	1.562-18 UNEF	(1.825) 46.35	(1.188) 30.17	(.812) 20.62
18	G (25)	1.562-18 UNEF	(1.825) 46.35	(1.250) 31.75	(.875) 22.23
19	G (25)	1.562-18 UNEF	(1.825) 46.35	(1.380) 35.05	(1.000) 25.4
20	H (29)	1.875-16 UNS	(2.143) 54.43	(1.188) 30.17	(.812) 20.62
21	H (29)	1.875-16 UNS	(2.143) 54.43	(1.380) 38.05	(1.000) 25.4
22	J (33)	2.062-16 UNS	(2.329) 59.16	(1.380) 38.05	(1.000) 25.4
23	J (33)	2.062-16 UNS	2.329) 59.16	(1.625) 41.28	(1.250) 31.75
24	A (11)	.750-20 UNEF	(1.028) 26.11	(.438) 11.12	(.281) 7.14
25	A (11)	.750-20 UNEF	(1.028) 26.11	(.562) 14.27	(.344) 8.74
26	B (13)	.875-30 UNEF	(1.141) 28.98	(.562) 14.27	(.344) 8.74
27	B (13)	.875-30 UNEF	(1.141) 28.98	(.625) 15.87	(.375) 9.52
28	C (15)	1.000-20 UNEF	(1.263) 32.08	(.625) 15.87	(.375) 9.52

Note: All dimensions are in mm (inches)

Dash Number	Designator	L ± .12 (± 3.05)	Working Room Ref.	V Thread Class 2*	X Max. Diameter	Y Ref
01	A (11)	(3.62) 91.55	(2.00) 50.80	.625-24 UNEF	(1.281) 32.53	(.938) 23.82
02	B (13)	(3.62) 91.55	(2.00) 50.80	.625-24 UNEF	(1.281) 32.53	(.938) 23.82
03	B (13)	(3.62) 91.55	(2.00) 50.80	.750-20 UNEF	(1.281) 32.53	(1.125) 28.57
04	C (15)	(3.62) 91.55	(2.00) 50.80	.625-24 UNEF	(1.281) 32.53	(.938) 23.82
05	C (15)	(3.62) 91.55	(2.00) 50.80	.750-20 UNEF	(1.281) 32.53	(1.125) 28.57
06	C (15)	(3.62) 91.55	(2.00) 50.80	.875-20 UNEF	(1.281) 32.53	(1.312) 33.32
07	C (15)	(4.12) 104.65	(2.50) 63.50	1.188-18 UNEF	(1.312) 33.32	(1.593) 40.46
08	D (17)	(4.12) 104.65	(2.50) 63.50	1.000-20 UNEF	(1.281) 32.54	(1.312) 33.32
09	D (17)	(4.12) 104.65	(2.50) 63.50	1.188-19 UNEF	(1.312) 33.32	(1.593) 40.46
10	D (17)	(4.12) 104.65	(2.50) 63.50	1.438-18 UNEF	(1.406) 35.71	(1.750) 44.45
11	E (19)	(4.12) 104.65	(2.50) 63.50	1.000-20 UNEF	(1.281) 32.54	(1.312) 33.32
12	E (19)	(4.12) 104.65	(2.50) 63.50	1.438-18 UNEF	(1.406) 35.71	(1.750) 44.45
13	F (23)	(4.62) 117.35	(3.00) 76.20	1.188-18 UNEF	(1.312) 33.32	(1.593) 40.46
14	F (23)	(4.62) 117.35	(3.00) 76.20	1.438-18 UNEF	(1.406) 35.71	(1.750) 44.45
15	F (23)	(4.62) 117.35	(3.00) 76.20	1.750-18 UNS	(1.593) 40.46	(2.093) 53.16
16	G (25)	(4.62) 117.35	(3.00) 76.20	1.438-18 UNEF	(1.406) 35.71	(1.750) 44.45
17	G (25)	(5.12) 130.05	(3.50) 88.90	1.750-18 UNS	(1.593) 40.46	(2.093) 53.16
18	G (25)	(5.12) 130.05	(3.50) 88.90	1.750-18 UNS	(1.593) 40.46	(2.093) 53.16
19	G (25)	(5.12) 130.05	(3.50) 88.90	2.000-18 UNS	(1.625) 41.28	(2.343) 59.51
20	H (29)	(5.12) 130.05	(3.50) 88.90	1.750-18 UNS	(1.593) 40.46	(2.093) 53.16
21	H (29)	(5.12) 130.05	(3.50) 88.90	2.000-18 UNS	(1.625) 41.28	(2.343) 59.51
22	J (33)	(5.12) 130.05	(3.50) 88.90	2.000-18 UNS	(1.625) 41.28	(2.343) 59.51
23	J (33)	(5.12) 130.05	(3.50) 88.90	2.250-16 UNS	(1.900) 48.26	(2.750) 69.85
24	A (11)	(3.62) 91.95	(2.00) 50.80	.750-20 UNEF	(1.281) 32.54	(1.125) 28.57
25	A (11)	(3.62) 91.95	(2.00) 50.80	.875-20 UNEF	(1.281) 32.54	(1.312) 33.32
26	B (13)	(3.62) 91.95	(2.00) 50.80	.875-20 UNEF	(1.281) 32.54	(1.312) 33.32
27	B (13)	(4.12) 104.65	(2.50) 63.50	1.000-20 UNEF	(1.281) 32.54	(1.312) 33.32
28	C (15)	(4.12) 104.65	(2.50) 63.50	1.000-20 UNEF	(1.281) 32.54	(1.312) 33.32

Note: All dimensions are in mm (inches)

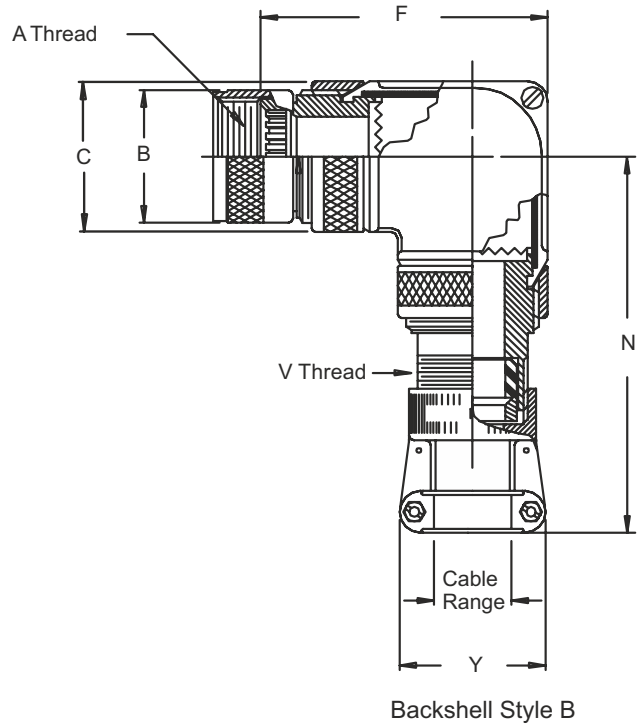
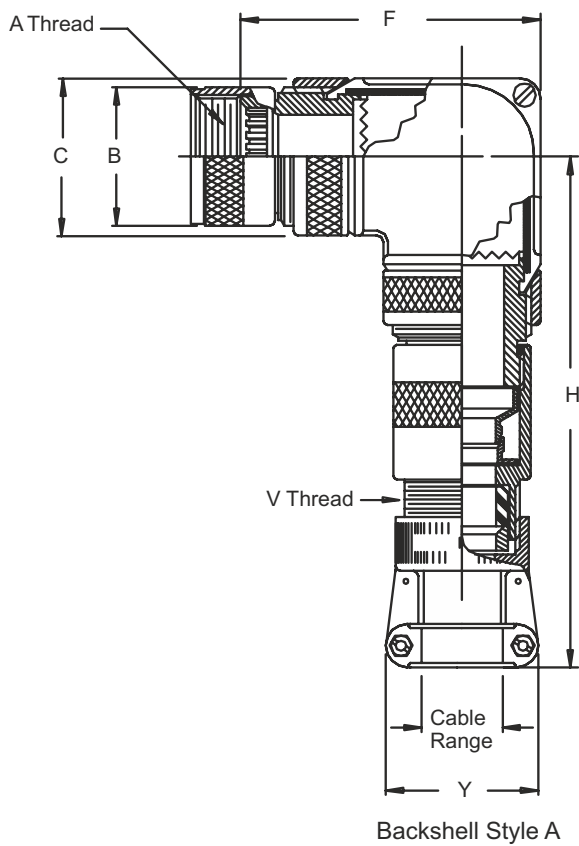
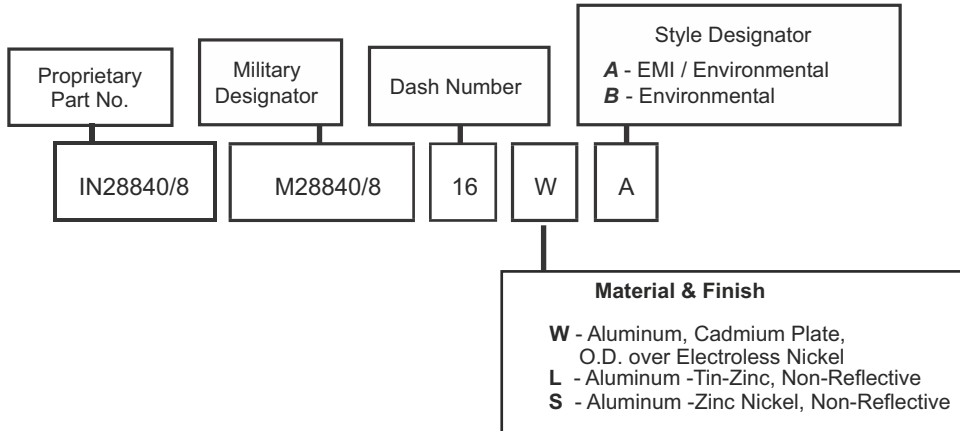

Note: All dimensions are in mm (inches)

Backshell Size	Dash Number	Designator	A Thread Class 2B	B Max. Diameter	C Max. Diameter	D Max. Diameter
A	01	A (11)	.750-20 UNEF	(1.028) 26.11	(1.188) 30.17	(1.031) 26.19
A	02	B (13)	.875-20 UNEF	(1.141) 28.98		
B	03	B (13)				
A	04	C (15)	1.00-20 UNEF	(1.263) 32.08	(1.438) 36.52	(1.156) 29.36
B	05	C (15)				
C	06	C (15)				
D	07	C (15)				
A	08	D (17)	1.125-18 UNEF	(1.387) 35.23	(1.688) 42.87	(1.281) 32.54
B	09	D (17)				
C	10	D (17)				
A	11	E (19)	1.250-18 UNEF	(1.513) 38.43	(1.938) 49.22	(1.406) 35.71
B	12	E (19)				
A	13	F (23)	1.438-18 UNEF	(1.703) 43.25		
B	14	F (23)				
C	15	F (23)				
A	16	G (25)	1.562-18 UNEF	(1.825) 46.35		
B	17	G (25)				
C	18	G (25)				
D	19	G (25)				
A	20	H (29)	1.875-16 UN	(2.143) 54.43		
B	21	H (29)				

Note: All dimensions are in mm (inches)

Backshell Size	Dash Number	Designator	X Ref. Dimension	Y Ref. Dimension	H Max. Style A	N Max. Style B
A	01	A (11)	(1.281) 32.54	(.938) 23.82	(5.332) 135.43	(2.962) 75.23
A	02	B (13)		(.938) 23.82	(5.332) 135.43	(2.962) 75.23
B	03	B (13)		(1.125) 28.57	(5.332) 135.43	(2.962) 75.23
A	04	C (15)		(.938) 23.82	(5.457) 138.61	(3.087) 78.41
B	05	C (15)		(1.125) 28.57	(5.457) 138.61	(3.087) 78.41
C	06	C (15)		(1.312) 33.32	(5.457) 138.61	(3.087) 78.41
D	07	C (15)		(1.593) 40.62	(5.682) 144.32	(3.312) 84.12
A	08	D (17)		(1.312) 33.32	(5.682) 144.32	(3.312) 84.12
B	09	D (17)	(1.312) 33.32	(1.593) 40.46	(5.713) 145.11	(3.343) 84.91
C	10	D (17)	(1.406) 35.71	(1.750) 44.45	(5.807) 147.50	(3.437) 87.30
A	11	E (19)	(1.281) 32.54	(1.312) 33.32	(5.682) 144.32	(3.312) 84.12
B	12	E (19)	(1.406) 35.71	(1.750) 44.45	(5.832) 148.13	(3.462) 87.93
A	13	F (23)	(1.312) 33.32	(1.593) 40.46	(5.738) 145.75	(3.368) 85.55
B	14	F (23)	(1.406) 35.71	(1.750) 44.45	(5.832) 148.13	(3.462) 87.93
C	15	F (23)	(1.593) 40.46	(2.093) 53.16	(6.019) 152.88	(3.649) 92.68
A	16	G (25)	(1.406) 35.71	(1.750) 44.45	(5.832) 148.13	(3.462) 87.93
B	17	G (25)	(1.593) 40.46	(2.093) 53.16	(6.019) 152.88	(3.649) 92.68
C	18	G (25)	(1.593) 40.46	(2.093) 53.16	(6.144) 156.06	(3.774) 95.86
D	19	G (25)	(1.625) 41.28	(2.343) 59.51	(6.176) 156.87	(3.806) 96.62
A	20	H (29)	(1.593) 40.46	(2.093) 53.16	(6.144) 156.06	(3.774) 95.86
B	21	H (29)	(1.625) 41.28	(2.343) 59.51	(6.176) 156.87	(3.806) 96.62

Note: All dimensions are in mm (inches)

Backshell Size	Dash Number	Designator	Cable Range		E Max. Dim.	F Max. DIM.	V Thread 2	
			Max.	Min.				
A	01	A (11)	(.312) 7.92	(.188) 4.77	(1.156) 29.36	(2.614)	.625-24 UNEF	
A	02	B (13)	(.312) 7.92	(.188) 4.77		66.40	.625-24 UNEF	
B	03	B (13)	(.438) 11.12	(.281) 7.14		.750-20 UNEF		
A	04	C (15)	(.312) 7.92	(.188) 4.77	(1.281) 32.54	(2.864)	.625-24 UNEF	
B	05	C (15)	(.438) 11.12	(.281) 7.14		72.75	.750-20 UNEF	
C	06	C (15)	(.562) 14.27	(.344) 8.74		.875-20 UNEF		
D	07	C (15)	(.750) 19.05	(.438) 11.12	(1.406) 35.71	(3.114) 79.10	1.188-18 UNEF	
A	08	D (17)	(.625) 15.87	(.375) 9.52			1.000-20 UNEF	
B	09	D (17)	(.750) 19.05	(.438) 11.12			1.188-18 UNEF	
C	10	D (17)	(.938) 23.82	(.625) 15.87			(1.531) 38.89	1.438-18 UNEF
A	11	E (19)	(.625) 15.87	(.375) 9.52			(1.406) 35.71	1.00-20 UNEF
B	12	E (19)	(.938) 23.82	(.625) 15.87	(1.531) 38.89	(3.364) 85.45	1.438-18 UNEF	
A	13	F (23)	(.750) 19.05	(.438) 11.12	(1.406) 25.71		1.188-18 UNEF	
B	14	F (23)	(.938) 23.82	(.625) 15.87	(1.531) 38.89		1.438-18 UNEF	
C	15	F (23)	(1.188) 30.17	(.812) 20.62	(1.781) 45.24		1.750-18 UNEF	
A	16	G (25)	(.938) 23.82	(.625) 15.87	(1.531) 38.89		1.438-18 UNEF	
B	17	G (25)	(1.188) 30.17	(.812) 20.62	(1.781) 45.24		1.750-18 UNS	
C	18	G (25)	(1.250) 31.75	(.875) 22.23				
D	19	G (25)	(1.380) 35.05	(1.000) 25.40	(2.156) 54.76	(3.614) 91.80	2.000-16 UNS	
A	20	H (29)	(1.188) 30.17	(.812) 20.62	(1.781) 45.24		1.750-18 UNS	
B	21	H (29)	(1.380) 35.05	(1.000)25.40	(2.156) 54.76		2.000-18 UNS	

Note: All dimensions are in mm (inches)

Backshell Size	Dash Number	Designator	A Thread Class 2B	B Max. Diameter	C Max. Diameter	D Max. Diameter
A	22	J (33)	2.062-16 UNS	(2.329) 59.16	(2.688) 68.26	(1.781) 45.24
A	23	J (33)				
B	24	A (11)	.750-20 UNEF	(1.028) 26.11	(1.188) 30.17	(1.031) 26.19
C	25	A (11)			(1.438) 36.52	(1.156) 29.36
C	26	B (13)	.875-20 UNEF	(1.141) 28.98	(1.688) 42.87	(1.281) 32.54
D	27	B (13)				
E	28	C (15)	1.000-20 UNEF	(1.263) 32.08		

Backshell Size	Dash Number	Designator	Cable Range		E Max. Dimensions	F Max. Dimensions	V Thread Class 2
			Max.	Min.			
A	22	J (33)	(1.380) 35.05	(1.000) 25.40	(2.281) 57.94	(4.114) 104.50	2.000-18 UNS
A	23	J (33)	(1.625) 41.26	(1.250) 31.75			2.250-16 UNS
B	24	A (11)	(.438) 11.12	(.281) 7.14	(1.156) 29.36	(2.614) 66.40	.750-20 UNEF
C	25	A (11)	(.562) 14.27	(.344) 8.74	(1.281) 32.54	(2.864) 72.75	.875-20 UNEF
C	26	B (13)	(.562) 14.27	(.344) 8.74			
D	27	B (13)	(.625) 15.87	(.375) 9.52	(1.406) 35.71	(3.114) 79.10	1.000-20 UNEF
E	28	C (15)	(.625) 15.87	(.375) 9.50			

Backshell Size	Dash Number	Designator	X Ref. Dimensions	Y Ref. Dimensions	H Max. Style A	N Max. Style B
A	22	J (33)	(1.625) 41.28	(2.343) 59.51	(6.426) 163.22	(4.056) 103.02
A	23	J (33)	(1.900) 48.26	(2.750) 59.85	(6.701) 170.21	(4.33) 110.01
B	24	A (11)	(1.281) 32.54	(1.125) 28.57	(5.332) 135.43	(2.962) 75.23
C	25	A (11)		(5.457) 138.61	(3.087) 78.41	
C	26	B (13)		(5.457) 138.61	(3.087) 78.41	
C	27	B (13)		(5.682) 144.32	(3.312) 84.12	
B	28	C (15)		(1.312) 33.32	(5.682) 144.32	(3.312) 84.12

Note: All dimensions are in mm (inches)

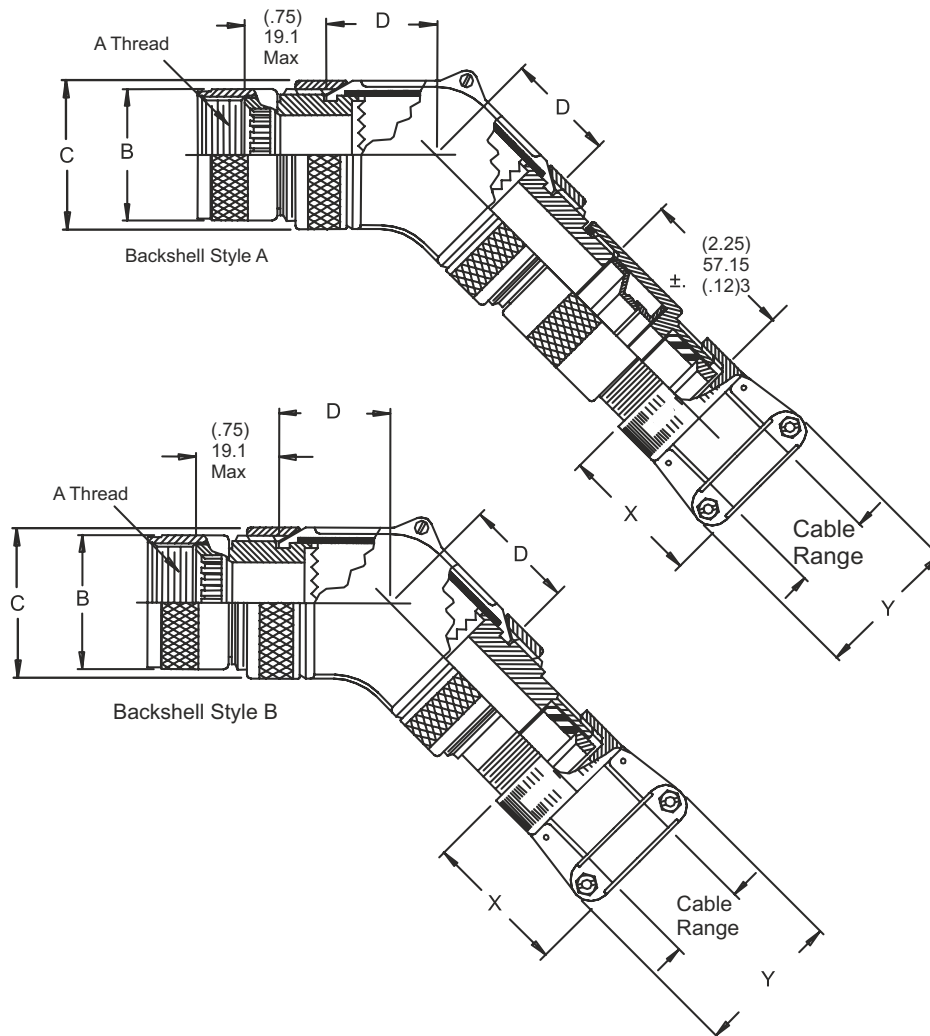
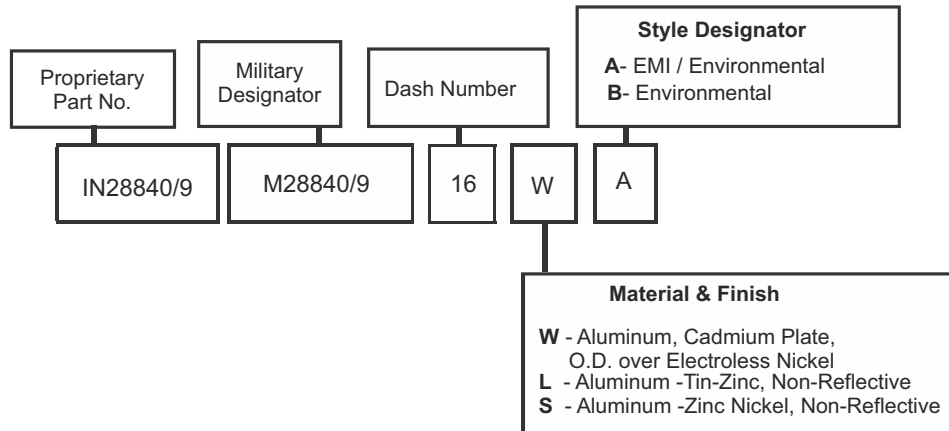

Note: All dimensions are in mm (inches)

Backshell Size	Dash Number	Designator	A Thread	B Max. Diameter	C Max. Diameter	D Max.
A	01	A (11)	.750-20 UNEF	(1.028) 26.11	(1.188) 30.18	(1.031) 26.19
A	02	B (13)	.875-20 UNEF	(1.141) 28.98		
B	03	B (13)				
A	04	C (15)	1.00-20 UNEF	(1.263) 32.08	(1.438) 36.53	(1.156) 29.36
B	05	C (15)				
C	06	C (15)				
D	07	C (15)				
A	08	D (17)	1.125-18 UNEF	(1.387) 35.23	(1.688) 42.88	(1.281) 32.54
B	09	D (17)				
C	10	D (17)				
A	11	E (19)	1.250-18 UNEF	(1.513) 38.43	(1.938) 49.23	(1.406) 35.71
B	12	E (19)				
A	13	F (23)	1.438-18 UNEF	(1.703) 43.51		
B	14	F (23)				
C	15	F (23)				
A	16	G (25)	1.562-18 UNEF	(1.825) 46.35	(2.188) 55.58	(1.531) 38.89
B	17	G (25)				
C	18	G (25)				
D	19	G (25)				
A	20	H (29)	1.875-16 UN	(2.143) 54.43		
B	21	H (29)				

Note: All dimensions are in mm (inches)

Backshell Size	Dash Number	Designator	Cable Range		E Max. Dim.	F Max. Style A	H Max. Style B
			Max.	Min.			
A	01	A (11)	(.312) 7.92	(.188) 4.77	(1.156) 29.36	(5.879) 149.33	(4.199) 106.65
A	02	B (13)	(.312) 7.92	(.188) 4.77		(5.879) 149.33	(4.199) 106.65
B	03	B (13)	(.438) 11.12	(.281) 7.14		(5.932) 150.67	(4.252) 108.00
A	04	C (15)	(.312) 7.92	(.188) 4.77	(1.281) 32.54	(6.092) 154.74	(4.412) 112.06
B	05	C (15)	(.438) 11.12	(.281) 7.14		(6.146) 156.11	(4.466) 113.44
C	06	C (15)	(.562) 14.27	(.344) 8.74		(6.202) 157.53	(4.522) 114.86
D	07	C (15)	(.750) 19.05	(.438) 11.12	(1.406) 35.71	(6.533) 165.94	(4.853) 123.27
A	08	D (17)	(.625) 15.87	(.375) 9.52		(6.413) 162.89	(4.733) 120.22
B	09	D (17)	(.750) 19.05	(.438) 11.12		(6.533) 165.94	(4.853) 123.27
C	10	D (17)	(.938) 23.82	(.625) 15.87	(1.531) 38.89	(6.636) 168.55	(4.956) 125.88
A	11	E (19)	(.625) 15.87	(.375) 9.52	(1.406) 35.71	(6.413) 162.89	(4.733) 120.22
B	12	E (19)	(.938) 23.82	(.625) 15.87	(1.531) 38.89	(6.846) 173.89	(5.166) 131.22
A	13	F (23)	(.750) 19.05	(.438) 11.12	(1.406) 25.71	(6.747) 171.37	(5.067) 128.70
B	14	F (23)	(.938) 23.82	(.625) 15.87	(1.531) 38.89	(6.846) 173.89	(5.166) 131.22
C	15	F (23)	(1.188) 30.17	(.812) 20.62	(1.781) 45.24	(7.103) 180.42	(5.423) 137.74
A	16	G (25)	(.938) 23.82	(.625) 15.87	(1.531) 38.89	(6.846) 173.89	(5.156) 130.96
B	17	G (25)	(1.188) 30.17	(.812) 20.62	(1.781) 45.24	(7.103) 180.42	(5.423) 137.74
C	18	G (25)	(1.250) 31.75	(.875) 22.23		(7.316) 185.83	(5.636) 143.15
D	19	G (25)	(1.380) 35.05	(1.000) 25.40	(2.156) 54.76	(7.425) 188.60	(5.745) 145.92
A	20	H (29)	(1.188) 30.17	(.812) 20.62	(1.781) 45.24	(7.316) 185.83	(5.636) 143.15
B	21	H (29)	(1.380) 35.05	(1.000) 25.40	(2.156) 54.76	(7.425) 188.60	(5.745) 145.92

Note: All dimensions are in mm (inches)

Backshell Size	Dash Number	Designator	V Thread Class	X Ref. Dimension	Y Ref. Dimension
A	01	A (11)	.625-24 UNEF	(1.281) 32.5	(.938) 23.82
A	02	B (13)	.625-24 UNEF		(.938) 23.82
B	03	B (13)	.750-20 UNEF		(1.125) 28.57
A	04	C (15)	.625-24 UNEF		(.938) 23.82
B	05	C (15)	.750-20 UNEF		(1.125) 28.57
C	06	C (15)	.875-20 UNEF		(1.312) 33.32
D	07	C (15)	1.188-18 UNEF	(1.312) 33.32	(1.593) 40.62
A	08	D (17)	1.000-20 UNEF	(1.281) 32.54	(1.312) 33.32
B	09	D (17)	1.188-18 UNEF	(1.312) 33.32	(1.593) 40.46
C	10	D (17)	1.438-18 UNEF	(1.406) 35.71	(1.750) 44.45
A	11	E (19)	1.000-20 UNEF	(1.281) 32.54	(1.312) 33.32
B	12	E (19)	1.438-18 UNEF	(1.406) 35.71	(1.750) 44.45
A	13	F (23)	1.188-18 UNEF	(1.312) 33.32	(1.593) 40.62
B	14	F (23)	1.438-18 UNEF	(1.406) 35.71	(1.750) 44.45
C	15	F (23)	1.750-18 UNS	(1.593) 40.46	(2.093) 53.16
A	16	G (25)	1.438-18 UNEF	(1.406) 35.71	(1.750) 44.45
B	17	G (25)	1.750-18 UNS	(1.593) 40.46	(2.093) 53.16
C	18	G (25)	1.750-18 UNS	(1.593) 40.46	(2.093) 53.16
D	19	G (25)	2.000-16 UNS	(1.625) 41.28	(2.343) 59.51
A	20	H (29)	1.750-18 UNS	(1.593) 40.46	(2.093) 53.16
B	21	H (29)	2.000-18 UNS	(1.625) 41.28	(2.343) 59.51

Note: All dimensions are in mm (inches)

Backshell Size	Dash Number	Designator	A Thread	B Max. Diameter	C Max. Diameter	D Max.
A	22	J (33)	2.062-16 UNEF	(2.329) 59.16	(2.688) 68.28	(1.781) 45.24
B	23	J (33)				
B	24	A (11)	.750-20 UNEF	(1.028) 26.11	(1.188) 30.18	(1.031) 26.19
C	25	A (11)				
C	26	B (13)	.875-20 UNEF	(1.141) 28.98	(1.438) 36.53	(1.156) 29.36
D	27	B (13)				
E	28	C (15)	1.000-20 UNEF	(1.263) 32.08	(1.688) 42.88	(1.281) 32.54

Backshell Size	Dash Number	Designator	Cable Range		E Max. Dimension	F Max. Style A	H Max. Style B
			Max.	Min.			
A	22	J (33)	(1.380) 35.05	(1.000) 25.40	(2.281) 57.94	(7.852) 199.44	(6.127) 156.77
B	23	J (33)	(1.625) 41.28	(1.250) 31.75		(6.454) 163.93	(6.454) 163.93
B	24	A (11)	(.438) 11.12	(.281) 7.14	(1.156) 29.36	(5.932) 150.67	(4.252) 108.00
C	25	A (11)	(.562) 14.27	(.344) 8.74	(1.281) 32.54	(6.202) 157.53	(4.522) 114.86
C	26	B (13)	(.562) 14.27	(.344) 8.74	(1.281) 32.54	(6.202) 157.53	(4.522) 114.86
D	27	B (13)	(.625) 15.87	(.375) 9.52	(1.406) 35.71	(6.413) 162.89	(4.733) 120.22
E	28	C (15)	(.625) 15.87	(.375) 9.50		(6.413) 162.89	(4.733) 120.22

Backshell Size	Dash Number	Designator	V Thread Class	X Ref. Dimension	Y Ref. Dimension
A	22	J (33)	2.000-18 UNS	(1.625) 41.28	(2.343) 59.51
B	23	J (33)	2.250-16 UNS	(1.900) 48.26	(2.750) 69.85
B	24	A (11)	.750-20 UNEF	(1.281) 32.54	(1.125) 28.57
C	25	A (11)	.875-20 UNEF		
C	26	B (13)	.875-20 UNEF		
D	27	B (13)	1.000-20 UNEF		
E	28	C (15)	1.000-20 UNEF		

Note: All dimensions are in mm (inches)

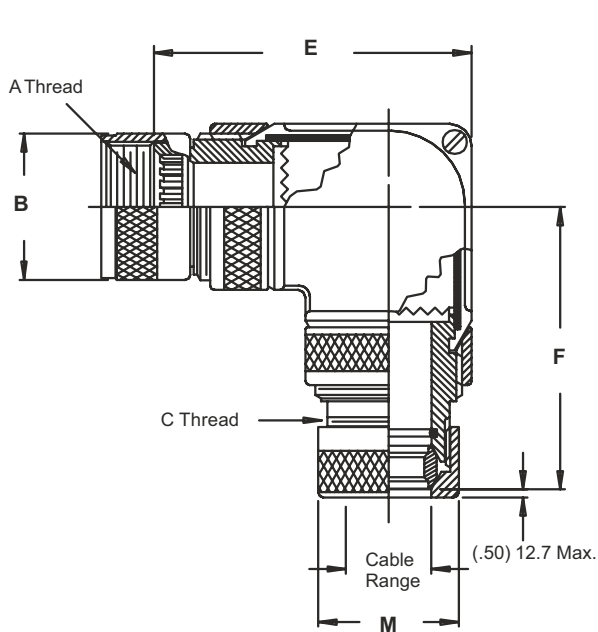
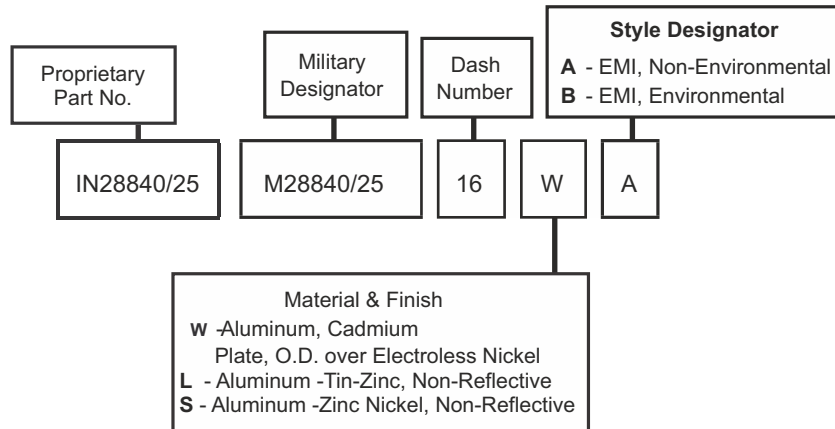

Style A- EMI/Non-Environmental
(Plain Conduit)

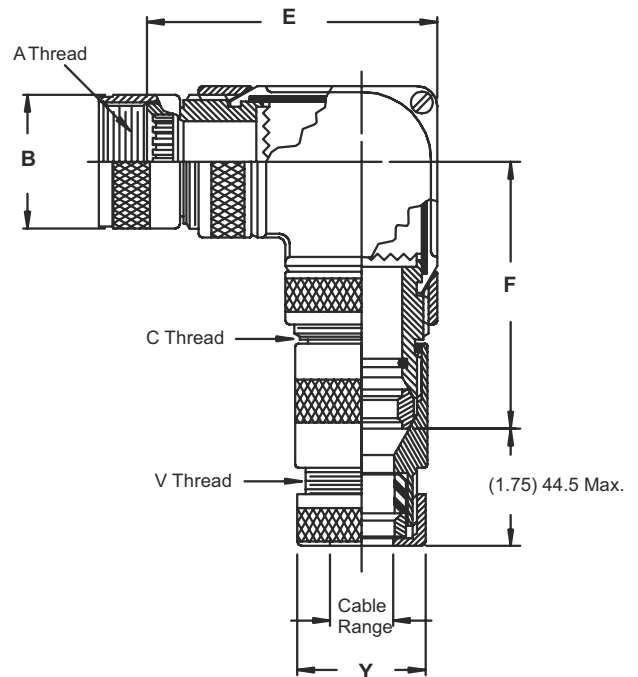

Style B- EMI/Non-Environmental
(Jacket Conduit)

Note: All dimensions are in mm (inches)

Dash Number	Designator	A Thread Class 2B	B Diameter Max.	C Thread Class 1	D Max Diameter	Sealing Range	
						Max.	Min.
01	A (11)	.750-20 UNEF	(1.028) 26.11	.875-20 UNEF	(1.031) 26.19	(.63) 16.0	(.50) 12.7
02	B (13)	.875-20 UNEF	(1.141) 28.98	.875-20 UNEF		(.63) 6.0	(.50) 12.7
03				1.000-20 UNEF		(.75) 19.1	(.63) 16.0
04	C (15)	1.000-20 UNEF	(1.263) 32.08	.875-20 UNEF	(1.281) 32.58	(.63) 16.0	(.50) 12.7
05				1.000-20 UNEF		(.75) 19.1	(.63) 16.0
06				1.125-18 UNEF		(.88) 22.4	(.75) 19.1
07				1.250-18 UNEF		(1.00) 25.4	(.88) 22.4
08	D (17)	1.125-18 UNEF	(1.387) 35.23	1.125-18 UNEF	(1.531) 38.89	(.88) 22.4	(.75) 19.1
09				1.250-18 UNEF		(1.00) 25.4	(.88) 22.4
10				1.625-18 UNEF		(1.38) 35.1	(1.19) 30.2
11	E (19)	1.250-18 UNEF	(1.513) 38.43	1.125-18 UNEF	(1.781) 45.24	(.88) 22.4	(.75) 19.1
12				1.250-18 UNEF		(1.00) 25.4	(.88) 22.4
13				1.625-18 UNEF		(1.38) 35.1	(1.19) 30.2
14				1.250-18 UNEF		(1.00) 25.4	(.88) 8 22.4
15	F (23)	1.438-18 UNEF	(1.703) 43.26	1.625-18 UNEF	(1.781) 45.24	(1.38) 35.1	(1.18) 30.2
16				1.875-18 UNS		(1.63) 41.4	(1.44) 36.6
17				1.250-18 UNEF		(1.00) 25.4	(.88) 22.4
18	G (25)	1.562-18 UNEF	(1.825) 46.35	1.625-18 UNEF	(2.031) 51.59	(1.38) 35.1	(1.19) 30.2
19				1.875-18 UNS		(1.63) 41.4	(1.44) 36.5
20				2.125-16 UN		(1.88) 47.8	(1.63) 41.4
21	H (29)	1.875-16 UN	(2.143) 54.43	1.875-18 UNS	(2.031) 51.59	(1.63) 41.4	(1.44) 36.6
22				2.125-16 UN		(1.33) 47.8	(1.63) 41.4
23	J (33)	2.062-16 UNS	(2.329) 59.16	2.125-16 UN	(2.531) 64.29	(1.88) 47.8	(1.63) 41.4
24				2.750-16 UN		(2.38) 60.5	(2.13) 54.1
25	A (11)	.750-20 UNEF	(1.028) 26.11	.875-20 UNEF	(1.031) 25.19	(.75) 19.5	(.63) 16.0

Note: All dimensions are in mm (inches)

Dash Number	Designator	Conduit Size M28840/4	E Max. Dim.	F Max. Dim.	V Thread Class 2	M Max. Dia.	Y Max. Dia.
01	A (11)	03	(2.36) 59.9	(3.50) 88.9	1.000-20 UNEF	(1.12) 28.5	(1.19) 30.23
02	B (13)	03			1.000-20 UNEF	(1.12) 28.5	(1.19) 30.23
03		04			1.188-18 UNEF	(1.25) 31.8	(1.38) 35.1
04	C (15)	03	(2.56) 65.0	(3.69) 93.72	1.000-20 UNEF	(1.12) 28.5	(1.39) 35.3
05		04			1.118-18 UNEF	(1.25) 31.8	(1.38) 35.1
06		05			1.438-18 UNEF	(1.43) 36.3	(1.63) 41.4
07		06			(2.67) 67.8	(3.81) 96.78	1.750-18 UNS
08	05	1.438-18 UNEF	(1.43) 36.3	(1.63) 41.4			
09	D (17)	06	1.750-18 UNS	(1.62) 41.15			(1.94) 49.3
10		08	2.00-18 UNS	(1.81) 46.0			(2.19) 55.6
11	E (19)	05	(3.05) 77.5	(4.19) 106.42	1.438-18 UNEF	(1.43) 36.3	(1.63) 41.4
12		06			1.750-18 UNS	(1.62) 41.2	(1.94) 49.3
13		08			2.00-18 UNS	(1.81) 46.0	(2.19) 55.6
14	F (23)	06	(3.05) 77.5	(4.19) 106.42	1.750-18 UNS	(1.62) 41.2	(1.94) 49.3
15		08			2.00-18 UNS	(1.81) 46.0	(2.19) 55.6
16		10			2.250-18 UN	(2.18) 55.4	(2.44) 62.0
17	G (25)	06	(3.05) 77.5	(4.19) 106.42	1.750-18 UNS	(1.62) 41.2	(1.94) 49.3
18		08			2.00-18 UN	(1.81) 46.0	(2.19) 55.6
19		10			2.250-18 UN	(2.18) 55.4	(2.44) 62.0
20		12			(3.33) 84.6	(4.50) 114.3	2.500-16 UN
21	H (29)	10	(3.33) 84.6	(4.50) 114.3	2.250-16 UN	(2.18) 55.4	(2.44) 62.00
22		12			1.500-16 UN	(2.56) 65.0	(2.69) 68.3
23	J (33)	12	(3.70) 94.0	(4.43) 112.52	2.500-16 UN	(2.56) 65.0	(2.69) 68.3
24		16			3.00-16 UN	(3.06) 77.8	(3.19) 81.0
25	A (11)	04	(2.36) 59.9	(3.50) 88.9	1.188-18 UNF	(1.25) 31.8	(1.38) 35.1

Note: All dimensions are in mm (inches)

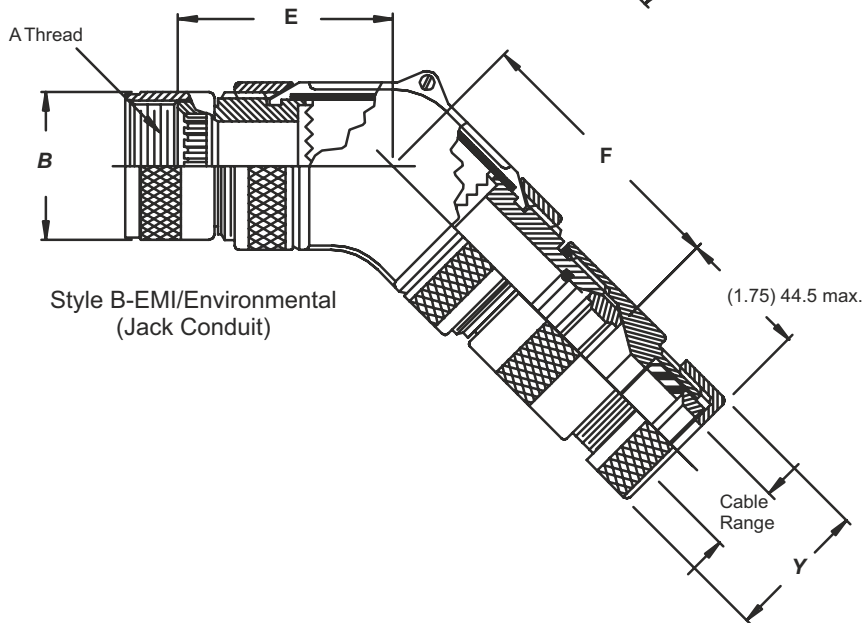
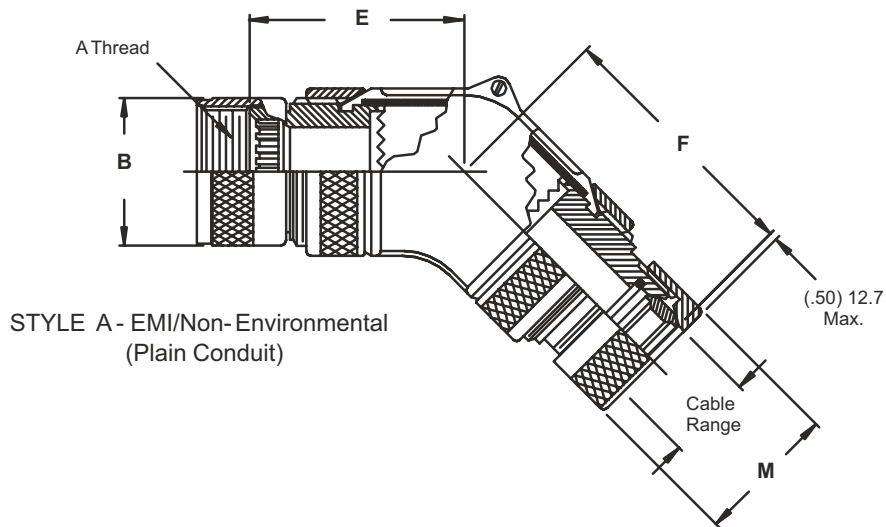
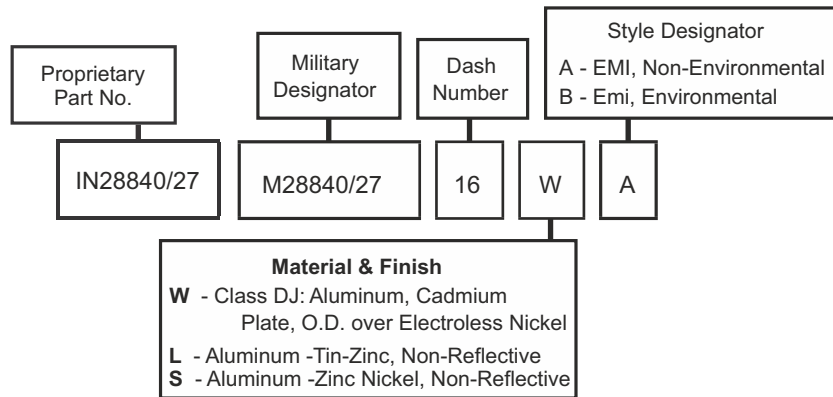

Note: All dimensions are in mm (inches)

Dash No.	Designator	A Thread Class 2B	B Max Diameter	C Thread Class 2	D Max. Diameter	Sealing Range		Conduit Size M 04	E Max. Dim.
						Max.	Min.		
01	A (11)	.750-20 UNEF	(1.028) 26.11	.875-20 UNEF	(1.031) 26.19	(.63) 16.0	(.50) 12.7	03	(2.36) 59.9
02	B (13)	.875-20 UNEF	(1.141) 28.98	.875-20 UNEF		(.63) 16.0	(.50) 12.7	03	
03				1.000-20 UNEF		(.75) 19.1	(.63) 16.0	04	
04	C (15)	1.000-20 UNEF	(1.263) 32.08	.875-20 UNEF	(1.281) 32.50	(.63) 16.0	(.50) 12.7	03	(2.56) 65.0
05				1.000-20 UNEF		(.75) 19.1	(.63) 16.0	04	
06				1.125-18 UNEF		(.88) 22.4	(.75) 19.1	05	
07				1.250-18 UNEF	(1.00) 25.4	(.88) 22.4	06		
08	D (17)	1.125-18 UNEF	(1.387) 38.23	1.125-18 UNEF	(1.531) 38.89	(.88) 22.4	(.75) 19.1	05	(2.67) 67.8
09				1.250-18 UNEF		(1.00) 25.4	(.88) 22.4	06	
10				1.625-18 UNEF		(1.38) 35.1	(1.19) 30.22	08	
11	E (19)	1.250-18 UNEF	(1.513) 38.43	1.125-18 UNEF		(.88) 22.4	(.75) 19.1	05	
12				1.250-18 UNEF		(1.00) 25.4	(.88) 22.4	06	
13				1.625-18 UNEF	(1.38) 35.1	(1.19) 30.2	08		
14	F (23)	1.438-18 UNEF	(1.703) 43.26	1.250-18 UNEF	(1.781) 45.24	(1.000) 25.4	(.88) 22.4	06	(3.05) 77.5
15				1.625-18 UNEF		(1.38) 35.1	(1.19) 30.2	08	
16				1.875-18 UNS		(1.63) 41.4	(1.44) 36.6	10	
17	G (25)	1.562-18 UNEF	(1.825) 46.35	1.250-18 UNEF		(1.00) 25.4	(.88) 22.4	06	
18				1.625-18 UNEF		(1.38) 41.4	(1.19) 30.2	08	
19				1.875-18 UNS	(1.43) 36.3	(1.44) 36.6	10		
20				2.125-16 UN	(1.88) 47.8	(1.63) 41.4	12		
21	H (29)	1.875-16 UN	(2.143) 54.43	1.875-18 UNS	(2.031) 51.59	(1.63) 41.4	(1.44) 36.6	10	(3.33) 84.6
22				2.125-16 UN		(1.88) 47.8	(1.63) 41.4	12	
23	J (33)	2.062-16 UNS	(2.329) 50.16	2.125-16 UN	(2.531) 64.29	(1.88) 47.8	(1.63) 41.4	12	(3.70) 94.0
24				2.750-16 UN		(2.38) 60.5	(2.13) 54.1	16	
25	A (11)	.750-20 UNEF	(1.028) 26.11	.875-20 UNEF	(1.031) 26.19	(.75) 19.1	(.63) 16.0	04	(2.36) 59.9

Note: All dimensions are in mm (inches)

Dash Number	Designator	F Max. Dim.	V Thread Class 2	M Max. Diameter	Y Max. Diameter
1	A (11)	(3.50) 88.9	1.000-20 UNEF	(1.12) 28.5	(1.19) 30.23
2	B (13)		1.000-20 UNEF	(1.12) 28.5	(1.19) 30.23
3			1.188-18 UNEF	(1.25) 31.8	(1.38) 35.1
4	C (15)	(3.69) 93.7	1.000-20 UNEF	(1.12) 28.5	(1.19) 30.23
5			1.188-18 UNEF	(1.25) 31.8	(1.38) 35.1
6			1.438-18 UNEF	(1.43) 36.3	(1.63) 41.4
7	D (17)	(3.81) 96.7	1.750-18 UNS	(1.62) 41.2	(1.94) 49.3
8			1.438-18 UNEF	(1.43) 36.3	(1.63) 41.4
9			1.750-18 UNS	(1.62) 41.2	(1.94) 49.3
10			2.00-18 UNS	(1.81) 46.0	(2.19) 55.6
11	E (19)	(4.19) 106.4	1.438-18 UNEF	(1.43) 36.3	(1.63) 41.4
12			1.750-18 UNS	(1.62) 41.2	(1.94) 49.3
13			2.00-18 UNS	(1.81) 46.0	(2.19) 55.6
14	F (23)	(4.19) 106.4	1.750-18 UNS	(1.62) 41.2	(1.94) 49.3
15			2.00-18 UN	(1.81) 46.0	(2.19) 55.6
16			2.250-16 UN	(2.18) 55.4	(2.44) 62.0
17			1.750-18 UNS	(1.62) 41.2	(1.94) 49.3
18	G (25)	(4.50) 114.3	2.00-18 UN	(1.81) 46.0	(2.19) 55.6
19			2.250-16 UN	(2.18) 55.4	(2.44) 62.0
20			2.500-16 UN	(2.56) 65.0	(2.69) 68.3
21	H (29)	(4.50) 114.3	2.250-16 UN	(2.18) 55.4	(2.44) 62.0
22			2.500-16 UN	(2.56) 65.0	(2.69) 68.3
23	J (33)	(4.83) 122.6	2.500-16 UN	(2.56) 65.0	(2.69) 68.3
24			3.00-16 UN	(3.06) 77.8	(3.19) 81.0
25	A (11)	(3.50) 88.9	1.188-18 UNEF	(1.25) 31.8	(1.38) 35.1

Note: All dimensions are in mm (inches)

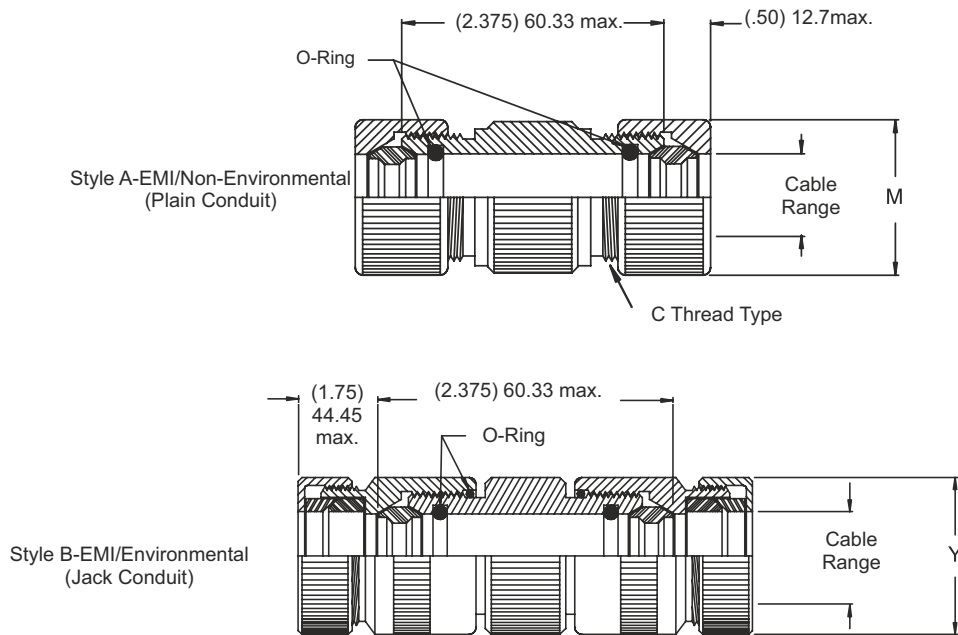
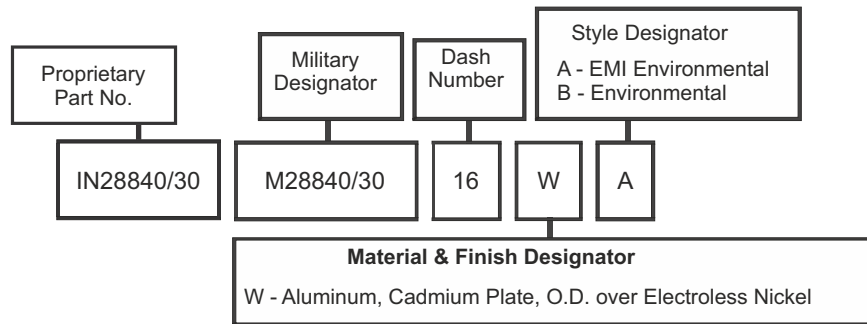

Dash Number	Conduit Size	Sealing Range		C Thread	M max. Diameter	V Thread Class 2	Y max. Diameter
		max.	min.				
03	03	(.63) 16.0	(.50) 12.7	.875-20 UNEF	(1.12) 28.5	1.00-20UNEF	(1.19) 30.23
04	04	(.75) 19.1	(.63) 16.0	1.000-20 UNEF	(1.25) 31.8	1.188-18 UNEF	(1.38) 35.1
05	05	(.88) 22.4	(.75) 19.05	1.125-18 UNEF	(1.43) 36.3	1.438-18 UNEF	(1.63) 41.4
06	06	(1.00) 25.4	(.88) 22.4	1.250-18 UNEF	(1.62) 41.2	1.750-18 UNS	(1.94) 49.3
08	08	(1.38) 35.1	(1.19) 30.2	1.625-18 UNEF	(1.81) 46.0	2.00-18 UNS	(2.19) 55.6
10	10	(1.63) 41.4	(1.44) 36.6	1.875-18 UNS	(2.18) 55.4	2.250-16 UN	(2.44) 62.0
12	12	(1.88) 47.8	(1.63) 41.4	2.125-16 UN	(2.56) 65.0	2.50-16 UN	(2.69) 68.3
16	16	(2.38) 60.5	(2.13) 54.1	2.750-16 UN	(3.06) 77.8	3.00-16 UN	(3.19) 81.0

Note: All dimensions are in mm (inches)

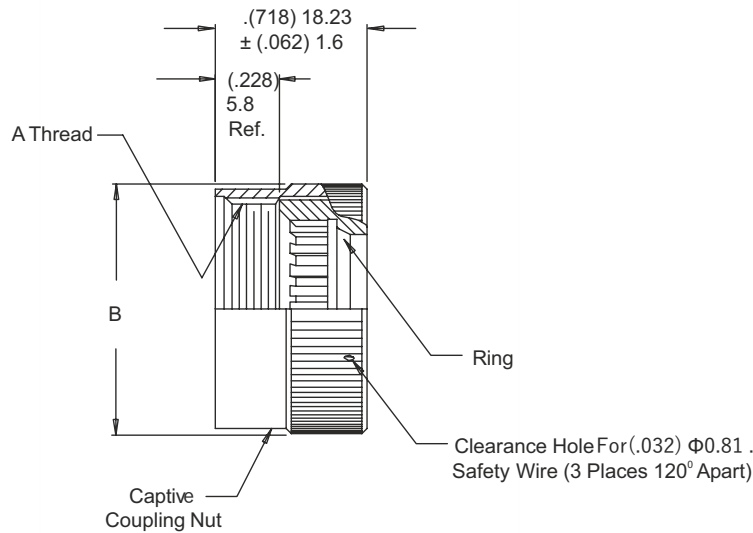
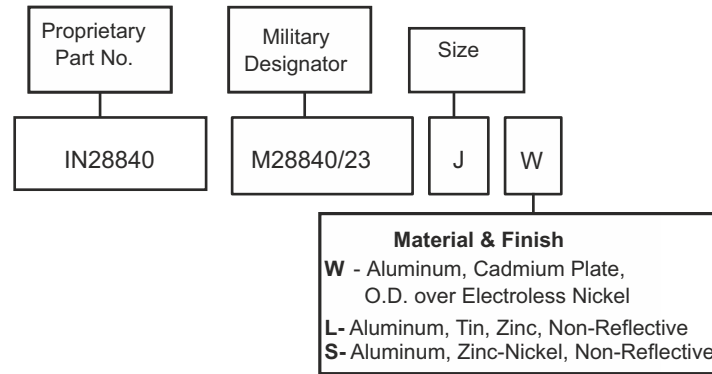

Designator	A Thread Class 2B	B Max. Diameter
A (11)	.750-20 UNEF	(1.028) 26.11
B (13)	.875-20 UNEF	(1.141) 28.98
C (15)	1.000-20 UNEF	(2.263) 32.08
D (17)	1.125-18 UNEF	(1.387) 35.23
E (19)	1.250-18 UNEF	(1.513) 38.43
F (23)	1.438-18 UNEF	(1.703) 43.25
G (25)	1.562-18 UNEF	(1.825) 46.35
H (29)	1.876-16 UN	(2.143) 54.43
J (33)	2.062-16 UNS	(2.329) 59.16

Note: All dimensions are in mm (inches)

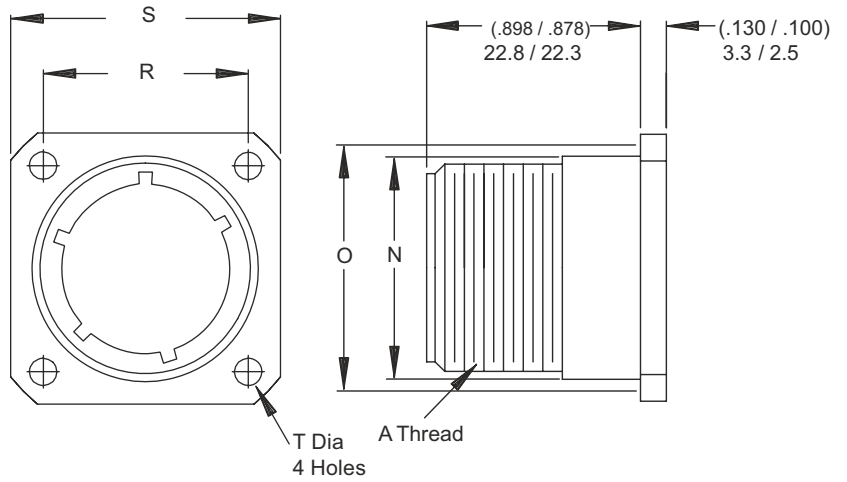
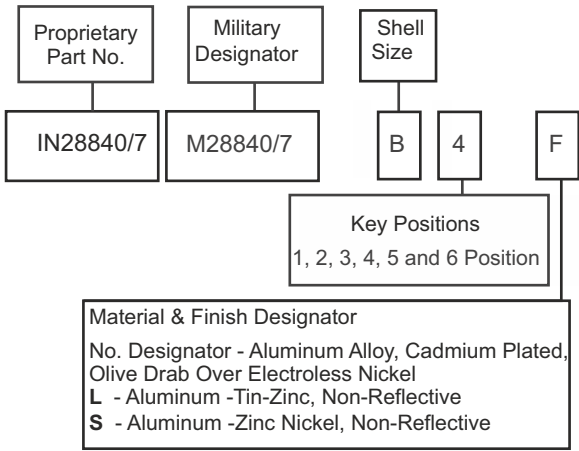

Designator	A Thread Class 2A	N Diameter Max.	O Reference Mating Hole	R T.P. Centerline to Centerline	S	T
A (11)	.750-.1P-2L-D.S.	(.750) 19.05	(.812) 20.62	(.750) 19.05	(1.043) 26.49 (1.003) 25.48	(.130) 3.30 (.115) 2.92
B (13)	.875-.1P-2L-D.S.	(.875) 22.22	(.937) 23.80	(.843) 21.41	(1.158) 29.41 (1.118) 28.40	
C (15)	1.062-.1P-.2L-D.S.	(1.062) 26.97	(1.124) 28.55	(.968) 24.59	(1.278) 32.46 (1.238) 31.45	
D (17)	1.125-.1P-.2L-D.S.	(1.125) 28.58	(1.187) 30.15	(1.015) 25.78	(1.403) (35.64 (1.363)34.62	
E (19)	1.312-.1P-.2L-D.S.	(1.312) 33.32	(1.374) 34.90	(1.140) 28.96	(1.528) 38.81 (1.488) 37.80	
F (23)	1.500-.1P-.2L-D.S.	(1.500) 38.10	(1.562) 39.67	(1.281) 32.54	(1.738) 44.15 (1.698) 43.13	
G (25)	1.625-.1P-2L-D.S.	(1.625) 41.28	(1.687) 42.85	(1.392) 35.36	(1.838) 46.69 (1.798) 45.67	(.157) 3.99 (.142) 3.61
H (29)	1.812-.1P-.2L-D.S.	(1.812) 46.02	(1.874) 47.60	(1.568) 39.83	(2.158) 54.81 (2.118) 53.80	
J (33)	2.000-.1P-2L-D.S.	(2.000) 50.80	(2.062) 52.37	(1.734) 44.04	(2.348) 59.64 (2.308) 58.62	(.183) 4.65 (.168) 4.27

Note: All dimensions are in mm (inches)

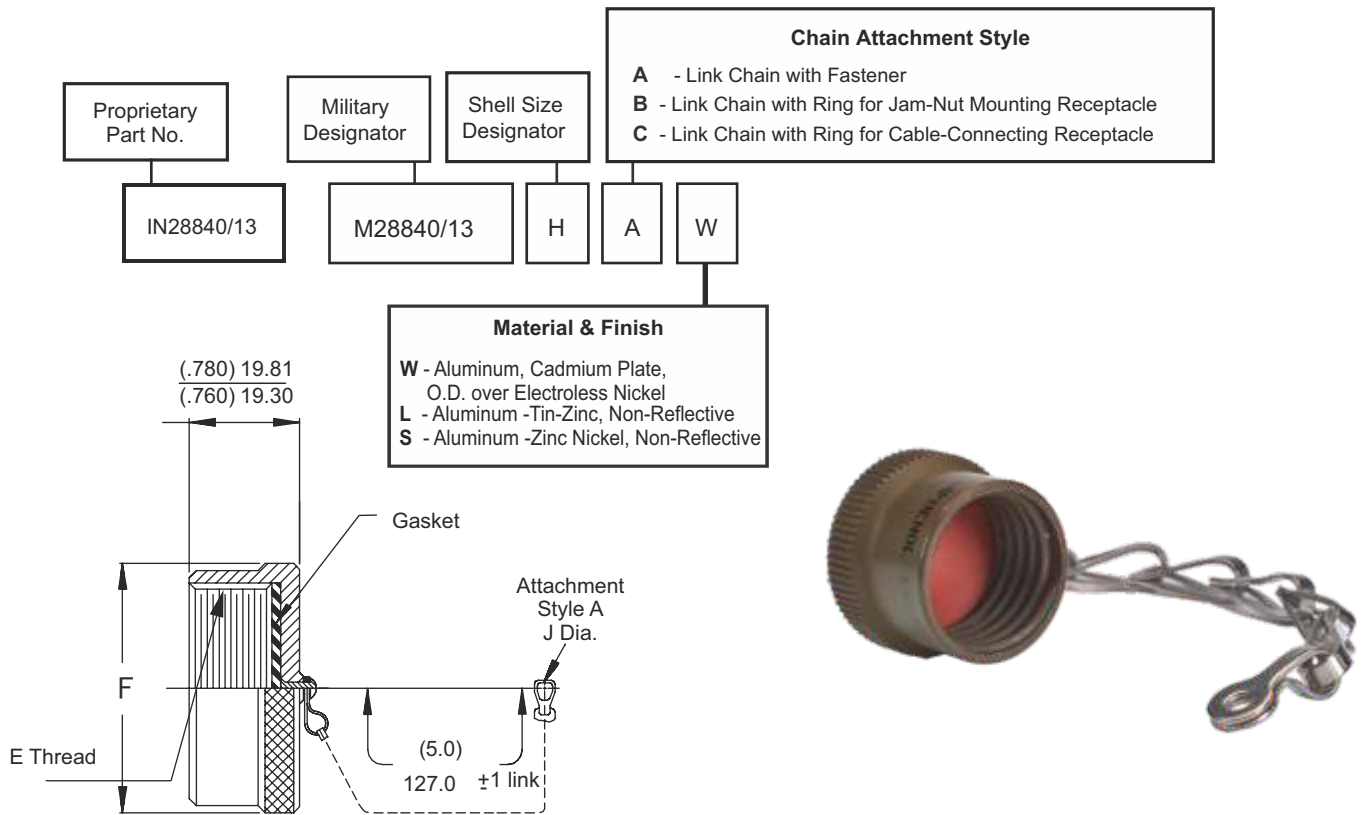

Designator	E Thread Class 2A	F Max. Diameter	J Dia (± 0.05) (± 0.13)
A (11)	.750-.1P-.2L-D.S.	(1.028) 26.21	(.130) 3.30
B (13)	.875-.1P-.2L-D.S.	(1.141) 23.98	
C (15)	1.062-.1P-.2L-D.S.	(1.263) 32.08	
D (17)	1.125-.1P-.2L-D.S.	(1.387) 35.23	
E (19)	1.312-.1P-.2L-D.S.	(1.513) 38.43	
F (23)	1.500-.1P-.2L-D.S.	(1.703) 43.26	(.156) 3.96
G (25)	1.625-.1P-.2L-D.S.	(1.825) 46.35	
H (29)	1.812-.1P-.2L-D.S.	(2.143) 54.43	
J (33)	2.000-.1P-.2L-D.S.	(2.329) 59.16	(.193) 4.90

Note: All dimensions are in mm (inches)

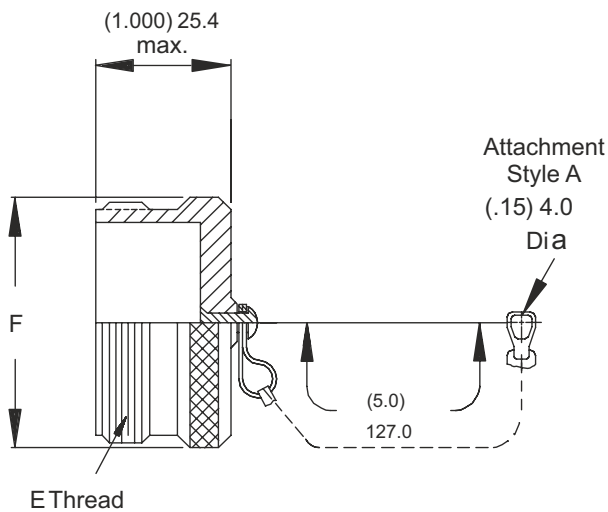
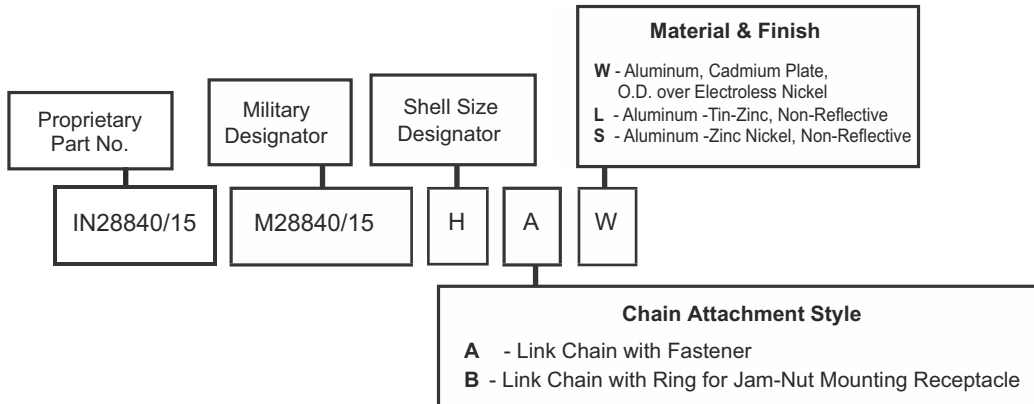

Designator	E Thread Class 2B	F Max. Diameter
A (11)	.750-1P-.2L-DS	(1.028) 26.21
B (13)	.875-1P-.2L-DS	(1.141) 28.98
C (15)	1.062-1P-.2L-DS	(1.263) 32.08
D (17)	1.125-1P-.2L-DS	(1.387) 35.23
E (19)	1.312-1P-.2L-DS	(1.513) 38.43
F (23)	1.500-1P-.2L-DS	(1.703) 43.26
G (25)	1.625-1P-.2L-DS	(1.825) 46.35
H (29)	1.812-1P-.2L-DS	(2.143) 54.43
J (33)	2.000-1P-.2L-DS	(2.329) 59.16

Note: All dimensions are in mm (inches)

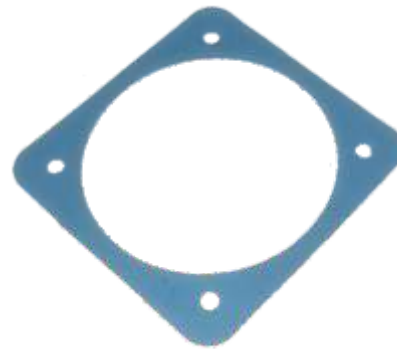
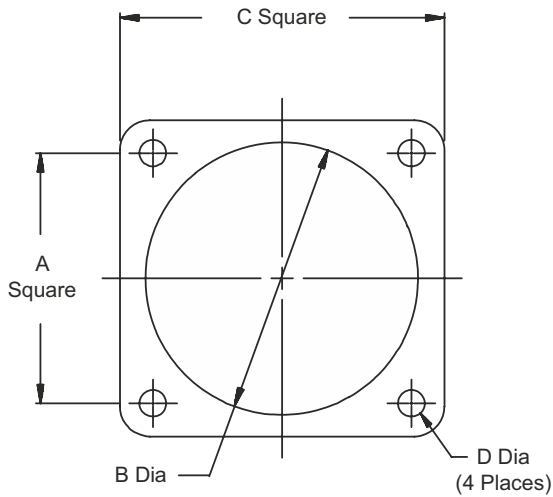
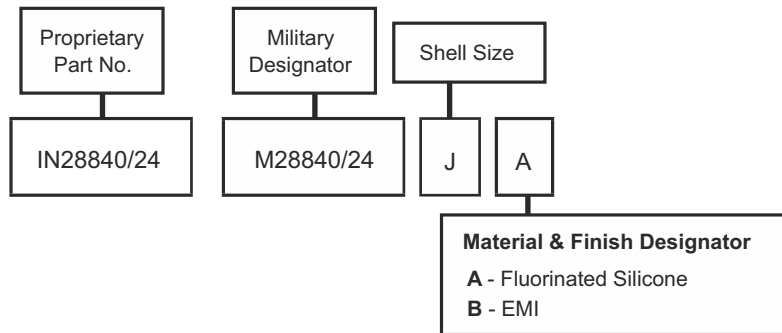

Designator	A	B Dia.	C	D Dia.
A (11)	(.760) 19.30 (.740) 18.80	(.766) 19.46 (.750) 19.05	(1.039) 26.39 (1.023) 25.98	(.130) 3.30 (.110) 2.79
B (13)	(.853) 21.67 (.833) 21.16	(.891) 22.63 (.875) 22.22	(1.154) 29.31 (1.138) 28.90	
C (15)	(.978) 24.84 (.958) 24.33	(1.078) 27.38 (1.062) 26.97	(1.274) 32.36 (1.258) 31.95	
D (17)	(1.025) 26.04 (1.005) 25.53	(1.141) 28.98 (1.125) 28.58)	(1.399) 35.53 (1.383) 35.13	
E (19)	(1.150) 29.21 (1.130) 28.70	(1.338) 33.98 (1.312) 33.32	(1.524) 38.71 (1.508) 38.30	
F (23)	(1.291) 32.79 (1.271) 32.28	(1.516) 38.51 (1.500) 38.10	(1.734) 44.04 (1.718) 43.64	
G (25)	(1.402) 35.61 (1.382) 35.10	(1.641) 41.68 (1.625) 41.28	(1.834) 46.58 (1.818) 46.18	(.157) 3.99 (.137) 3.48
H (29)	(1.578) 40.08 (1.558) 39.57	(1.891) 48.03 (1.875) 47.62	(2.154) 54.71 (2.138) 54.30	
J (33)	(1.744) 44.30 (1.724) 43.79	(2.078) 52.78 (2.062) 52.37	(2.344) 59.54 (2.328) 59.13	

Note: All dimensions are in mm (inches)

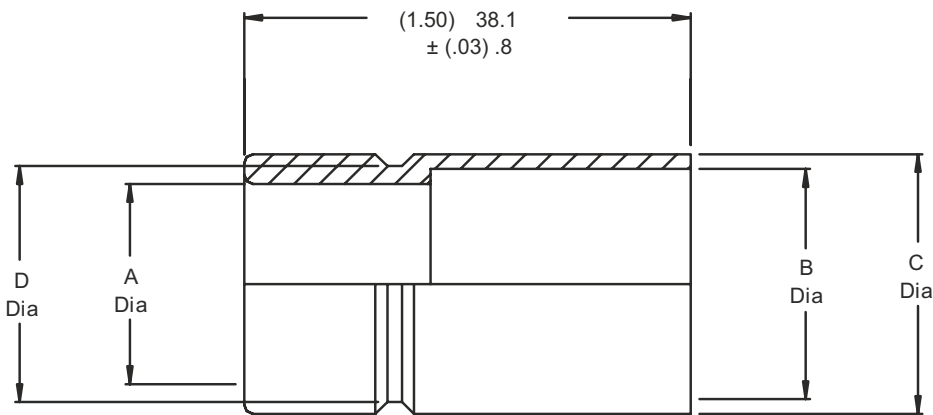
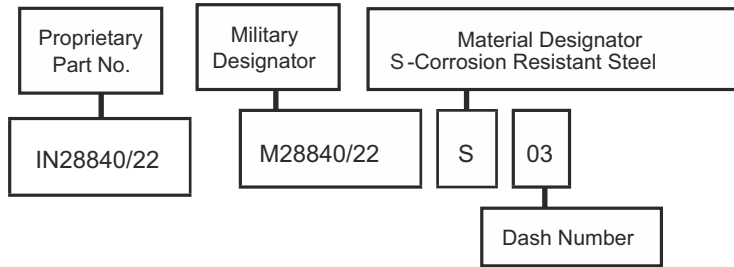

Size	MIL- DTL-28840/04 Size Ref.	A +0.5 (.02) -0.00 (.000)	B +0.12 (0.05) -0.00 (.000)	C +0.00 (.000) -0.12 (0.05)	D +0.00 (.000) - 0.12(0.05)
03	03	(.375) 9.53	(.540) 13.71	(.625) 15.87	(.525) 13.34
04	04	(.500) 12.70	(.665) 16.89	(.750) 19.05	(.650) 16.51
05	05	(.625) 15.87	(.780) 19.81	(.875) 22.23	(.775) 19.69
06	06	(.750) 19.05	(.940) 23.88	(1.000) 25.40	(.900) 22.86
08	08	(1.000) 25.40	(1.225) 31.12	(1.375) 34.93	(1.275) 32.39
10	10	(1.250) 31.75	(1.470) 37.34	(1.625) 41.28	(1.525) 38.74
12	12	(1.500) 38.10	(1.740) 44.20	(1.875) 47.65	(1.775) 45.09
16	16	(2.000) 50.80	(2.215) 56.26	(2.375) 60.33	(2.275) 57.79

Note: All dimensions are in mm (inches)

Standard Pin Crimp Contact For MIL-DTL-28840 Connectors

Mating End Size	Wire Accommodation	Military Part Number	Proprietary Part Number
20	28-32 AWG	M39029/83-451	IN39029 / 83-451
20	22-26 AWG	M39029/83-450	IN39029 / 83-450
20	20-24 AWG	M39029/83-508	IN39029 / 83-508

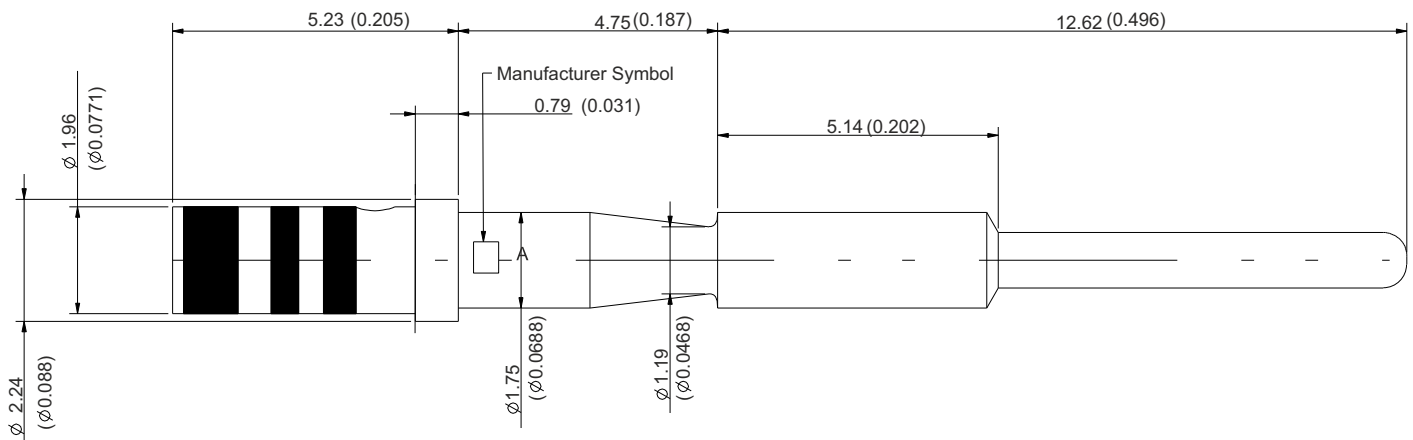
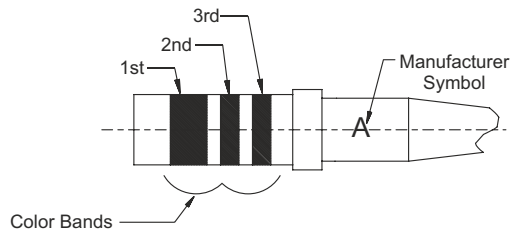

Material & Finish

Pin Contact: Copper Alloy per ASTM B197, 50 Micro inches Gold plated per ASTM B488 Type II Code C Class 1. 27 over nickel plate per QQ-N-290 Class 2, 50-100 micro inches.

Note: All dimensions are in mm (inches)

Table I: Contact Dimensions

Size	Proprietary Part Number	Military Number	Ø B	Ø C	Color Bands		
					1st	2nd	3rd
20	IN39029 / 83-508	M39029 / 83-508	(.050) 1.27 (.048) 1.21	(.032) 0.81 (.26) 0.66	Green	Black	Grey
20	IN39029 / 83-450	M39029 / 83-450	(.0355) 0.91 (.0335) 0.86	(.032) 0.81 (.026) 0.66	Yellow	Green	Black
20	IN39029 / 83-451	M39029 / 83-451	(.0200) 0.50 (.0180) 0.45	(.022) 0.56 (.018) 0.46	Yellow	Green	Brown

Table II: Tool Compatibility

Size	Proprietary Part Number	Military Number	AWG Handling	Crimp Tool	Positioner	Insertion Tool	Extraction Tool
20	IN39029/83-508	M39029/83-508	20, 22, 24	M22520/34-01	M22520/34-02	M81969/33-01	M81969/34-01
20	IN39029/83-450	M39029/83-450	22, 24, 26	M22520/34-01	M22520/34-02	M81969/33-01	M81969/34-01
20	IN39029/83-451	M39029/83-451	28, 30,32	M22520/34-01	M22520/34-02	M81969/33-01	M81969/34-01

Test

Performance Specifications

Durability	Meets SAE-AS39029, paragraph 3.5.9) No electrical or mechanical defects after 500 cycles of engagement & disengagement
Contact Retention	(Meets MIL-DTL-38999, paragraph 3.23) The axial displacement of the contact shall not exceed .012 inch (0.30 mm). No damage to contacts or inserts shall result.
Pin Engagement End	(Meets SAE-AS39029 paragraph 3.4.1) Unless otherwise specified, the mating end of all contacts (except size 22 and smaller) shall be formed with an approximate spherical radius.
Permeability	(Meets SAE-AS39029, paragraph 3.5.1) When tested as specified in paragraph 4.7.2, the relative magnetic permeability of the contact shall be no greater than 2.0.
Vibration	(Meets SAE-AS39029, paragraph 3.5.10) When contacts are tested as specified in paragraph 4.7.11, there shall be no electrical discontinuity of 1 microsecond or greater. There shall be no defects detrimental to the mechanical or electrical performance.
Salt Spray (corrosion)	(Meets SAE-AS39029, paragraph 3.5.12) When tested as specified in 4.7.13. mated contacts shall withstand 48 hours of salt spray conditioning without defects detrimental to the mechanical or electrical performance.
Temperature life	(Meets SAE-AS39029, paragraph 3.5.13) When tested as specified in paragraph 4. 7. 14, mated contacts shall withstand temperature conditioning for 1,000 hours without defects detrimental to mechanical or electrical performance. There shall be no diffusion/migration of the base metal through the contact outer plating Class A - Maximum operating temperature +125°C. per paragraph 1.2.2
Dielectric withstanding voltage	(Meets SAE-AS39029, paragraph 3.5.19) When tested as specified in paragraph 4.7.20, crimped contacts shall show no evidence of breakdown or flashover.
Workmanship	(Meets SAE-AS39029, paragraph 3.7) Contacts shall be processed in such a manner as to be uniform in quality and shall be free from foreign material & burrs or sharp corners that might damage the connector or affect mating of the contacts. Burrs & sharp edges shall be removed 0.005 inch max. (0.13mm)

Note: All dimensions are in mm (inches)

Standard Socket Crimp Contact for MIL-DTL-28840 Connectors

Mating End Size	Wire Accomodation	Military Part Number	Proprietary Part Number
20	28-32 AWG	M39029/84-453	IN39029/84-453
20	22-26 AWG	M39029/84-452	IN39029/84-452
20	20-24 AWG	M39029/84-509	IN39029/84-509

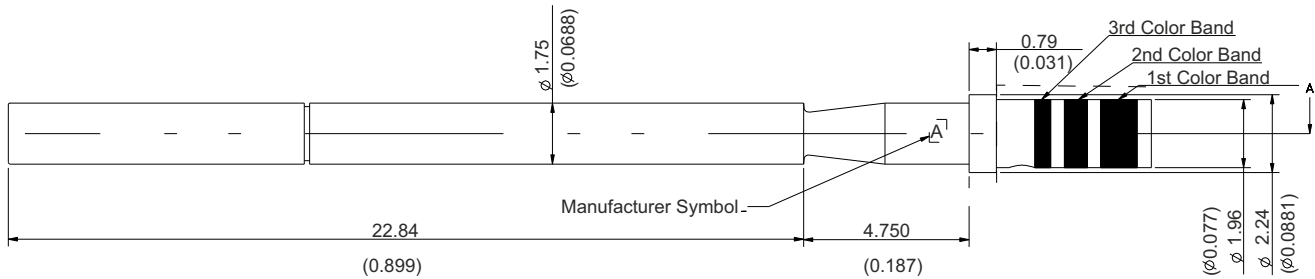
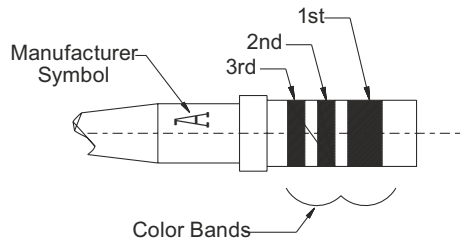

Material & Finish

Pin Contact: Copper Alloy per ASTM B197, 50 Micro inches Gold plated per ASTM B488 Type II Code C Class 1. 27 over nickel plate per QQ-N-290 Class 2, 50-100 micro inches.
 Socket Contact Hood: Stainless Steel, passivated per AMS-QQ-P-35.

Note: All dimensions are in mm (inches)

Table I: Contact Dimensions

Size	Proprietary Part Number	Military Number	Ø B	Ø C	Color Bands		
					1st	2nd	3rd
20	IN39029/84-509	M39029/84-509	(.050) 1.27 (.048) 1.21	(.032) 0.81 (.026) 0.66	Green	Black	White
20	IN39029/84-452	M39029/84-452	(.0355) 0.91 (.0335) 0.86	(.032) 0.81 (.026) 0.66	Yellow	Green	Red
20	IN39029/84-453	M39029/84-453	(.0200) 0.52 (.0180) 0.45	(.022) 0.56 (.018) 0.45	Yellow	Green	Orange

Table II: Tool Compatibility

Size	Proprietary Part Number	Military Number	AWG Handling	Crimp Tool	Positioner	Insertion Tool	Extraction Tool
20	IN39029/84-593	M39029/84-509	20, 22, 24	M22520/34-01	M22520/34-02	M81969/33-01	M81969/34-01
20	IN39029/84-452	M39029/84-452	22, 24, 26	M22520/34-01	M22520/34-02	M81969/33-01	M81969/34-01
20	IN39029/84-453	M39029/84-453	28, 30, 32	M22520/34-01	M22520/34-02	M81969/33-01	M81696/34-01

Test	Performance Specifications
Durability	(Meets SAE-AS39029, paragraph 3.5.9) No electrical or mechanical defects after 500 cycles of engagement and disengagement
Contact Retention	(Meets MIL-DTL-38999, paragraph 3.23) The axial displacement of the contact shall not exceed .012 inch (0.30 mm). No damage to contacts or inserts shall result.
Pin Engagement End	(Meets SAE-AS39029 paragraph 3.4.1) Unless otherwise specified, the mating end of all contacts (except size 22 and smaller) shall be formed with an approximate spherical radius.
Permeability	(Meets SAE-AS39029, paragraph 3.5.1) When tested as specified in paragraph 4.7.2, the relative magnetic permeability of the contact shall be no greater than 2.0.
Vibration	(Meets SAE-AS39029, paragraph 3.5.10) When contacts are tested as specified in paragraph 4.7.11, there shall be no electrical discontinuity of 1 microsecond or greater. There shall be no defects detrimental to the mechanical or electrical performance.
Salt Spray (corrosion)	(Meets SAE-AS39029, paragraph 3.5.12) When tested as specified in 4.7.13, mated contacts shall withstand 48 hours of salt spray conditioning without defects detrimental to the mechanical or electrical performance.
Temperature life	(Meets SAE-AS39029, paragraph 3.5.13) When tested as specified in paragraph 4.7.14, mated contacts shall withstand temperature conditioning for 1,000 hours without defects detrimental to mechanical or electrical performance. There shall be no diffusion/migration of the base metal through the contact outer plating. Class A - Maximum operating temperature +125°C. per paragraph 1.2.2
Dielectric withstanding voltage	(Meets SAE-AS39029, paragraph 3.5.19) When tested as specified in paragraph 4.7.20, crimped contacts shall show no evidence of breakdown or flashover.
Workmanship	(Meets SAE-AS39029, paragraph 3.7) Contacts shall be processed in such a manner as to be uniform in quality and shall be free from foreign material and burrs or sharp corners that might damage the connector or affect mating of the contacts. Burrs and sharp edges shall be removed 0.005 inch maximum (0.13mm).

Note: All dimensions are in mm (inches)

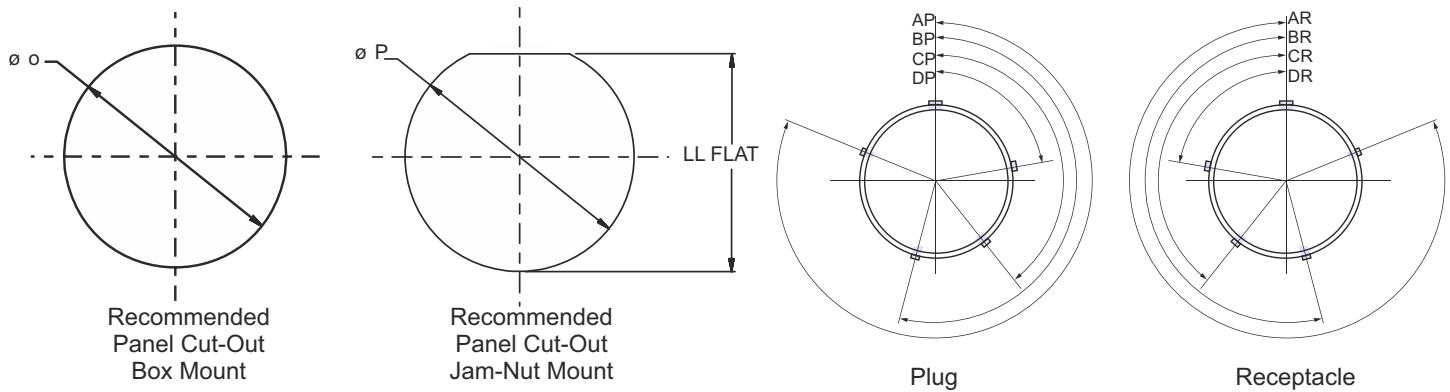

Table II: Alternate Keyways

Designator	P Dia.	LL Flat	O Ref. Mtg. Hole
A (11)	(.890)	(.853)	(.812) 20.62
	22.61	21.67	
	(.880)	(.843)	
	22.35	21.41	
B (13)	(1.015)	(.978)	(.937) 23.80
	25.78	24.84	
	(1.005)	(.968)	
	25.53	24.59	
C (15)	(1.203)	(1.165)	(1.124) 28.55
	30.55	29.59	
	(1.193)	(1.155)	
	30.3	29.34	
D (17)	(1.265)	(1.228)	(1.187) 30.15
	32.13	31.19	
	(1.255)	(1.218)	
	31.88	30.94	
E (19)	(1.453)	(1.415)	(1.374) 34.90
	36.91	35.94	
	(1.443)	1.405	
	36.65	35.69	
F (23)	(1.640)	(1.603)	(1.562) 39.67
	41.66	40.72	
	(1.630)	(1.593)	
	41.40	40.46	
G (25)	(1.765)	(1.728)	(1.687) 42.85
	44.83	43.89	
	(1.755)	(1.718)	
	44.57	43.64	
H (29)	(1.953)	(1.915)	(1.874) 47.60
	49.60	48.64	
	(1.943)	(1.905)	
	49.35	48.38	
J (33)	(2.140)	(2.103)	(2.062) 52.37
	54.36	53.42	
	(2.130)	(2.093)	
	54.10	53.16	

Designator	Key and Keyway Arrangement	AR° or AP° BSC	BR° or BP° BSC	CR° or CP° BSC	DR° or DP° BSC
A (11) B (13)	1	95	141	208	236
	2	113	156	182	292
	3	90	145	195	252
	4	53	156	220	255
	5	119	146	176	298
	6	51	141	184	242
C (15) D (17)	1	80	142	196	293
	2	135	170	200	310
	3	49	169	200	244
	4	66	140	200	257
	5	62	145	180	280
	6	79	153	197	272
E (19) F (23) G (25) H(29) J (33)	1	80	142	196	293
	2	135	170	200	310
	3	49	169	200	244
	4	66	140	200	257
	5	62	145	180	280
	6	79	153	197	272

Note: All Dimensions for reference only

Contact Insertion

1. Tools

Be sure that all proper assembly tools are on hand & properly calibrated (Pic. 1)



Picture 1

2. Stripping

Strip wire ends to 3/16" for 20-32 AWG, taking care not to nick or cut wire strands. (Pic. 2) Hold insulation & twist strands to eliminate any splaying.

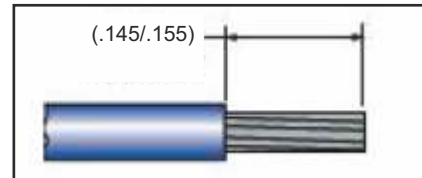

Picture 2

3. Wire Insertion

Insert wire into crimp well of contact. Don't force. Wire strands must be visible through inspection hole (Pic. 3).

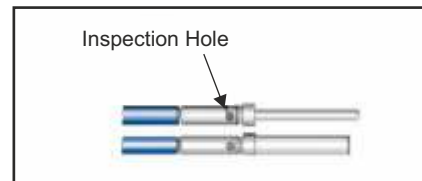

Picture 3

4. Crimping

Using crimp tool & positioner noted above insert wire & contact into locator jaws. Squeeze tool handle completely until ratchet releases. Remove wired contact from tool (Pic. 4).



Picture 4

5. Backshell Preparation

Slide backshell/strain relief over jacketed cable or wires in proper order for re-assembly. Contact factory for proper jacketed cable assembly (Pic. 5).



Picture 5

6. Contact Preparation

Slide wired contact into insertion tool of choice so that the tip of the tool butts against the shoulder of the contact. (Pic. 6).



Picture 6

1. Insertion of Contacts:

Insert wired contacts & tool into contact 'clicks' into retention clip (Pic. 7) A straight pull on the wire will assure the contact is properly seated. Note: Isopropyl alcohol may be used sparingly as a lubricant.

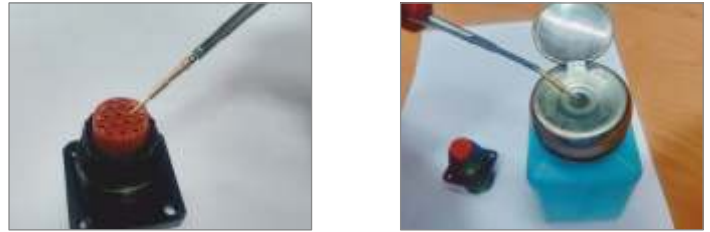

Picture 7

2. Assembly:

After all contacts are inserted, assemble backshell or strain relief according to Amphenol backshell catalog instructions.

Contact Extraction

1. Remove backshell or strain relief from connector.

2. Contact Extraction

MIL-DTL-28840 connector contacts are extracted from the rear but released from the front of the connector. Using an extraction tool, slide tool tip into front of contact cavity (Mating face of connector, Pic. 8) until tool tip engages against contact retention clip. Push plunger with min. force to release contact (Pic. 9). Note: Isopropyl alcohol may be used sparingly as a lubricant.



Picture 8

3. Contact Extraction

Pull wired contact from rear grommet of connector.



Picture 9

Contact Replacement

After replacing contact re-insert starting with assembly instructions number 7.

M22520/34-01 Basic Crimp Tool:

Qualified to M22520/34-01, this crimp tool prevents improper crimps and over crimping and is based on the AFM8 miniature adjustable crimp tool, it performs a modified eight impression crimp with a precision cycle controlled ratcheting mechanism for gas-tight wire terminations and excellent tensile strength. Also featured is a four-step crimp depth selector knob and is designed for use with the M22520/34-02 bayonet-type Positioner. Gaging is accomplished with the M22520/35 "Go/No-Go" Gauge. The adjustment wheel has eight settings. Check calibration with the M22520/35 gage. Length is 6.75 inches, weight is approximately 10oz.

**M22520/34-02 Positioner:**

This bayonet type positioned locates and holds contacts at the correct position for crimping with the M22520/34-01 Basic Crimp Tool. The face plate shows the correct tool settings.

**M22520/35 Gauge:**

Periodic Gauging is recommended to ensure accurate calibration and is easily accomplished by setting the tool selector knob to the proper position and checking the indenter closure with the M22520/35 "Go/No-Go" Gauge.

Insertion & Removal Tools**M81969/33-01 Straight Insertion Tool:**

M81969/33-01 Straight insertion tool is approved for use on MIL-DTL-28840 connectors and features an anodized aluminium handle and SS insertion tip.

**M81969/33-01 Offset Insertion Tool:**

Approved for use on MIL-DTL-28840 connectors, the M81969/33-02 Offset Insertion Tool features an anodized aluminium handle and SS offset insertion tip.

**M81969/34-01 Removal Tool:**

Designed and approved for removal of contacts and in MIL-DTL-28840 connectors the M81969/34-01 removal tool's anodized.

Notice: All information including illustrations given herein is believed to be accurate at the time of printing. In lieu of design advances Amphenol reserves the right to change specifications without notice. This Publication Ship Board Connectors 03 Rev. 02-24 Series Connectors supercedes all existing Amphenol literature on Ship Board Connectors Series Connectors.

NORTH AMERICA

Sales & Product Support

Amphenol PCD
72 Cherry Hill Drive
Beverly, MA 01915 USA
Tel: +1-978-624-3400
Fax: +1-978-927-1513
info@amphenolpcd.com
www.amphenolpcd.com
www.backshellworld.com

Amphenol Aerospace Operations
40-60, Delaware Avenue
Sidney, NY 13838-1395
Tel: +1-607-563-5011
Fax: +1-607-563-5357

Amphenol Canada
Meford Drive
Scarborough,
ON M1B 2X6
Tel: +416-291-4401
Fax: +416-292-0647

Amphenol Fiber Systems International
1300 Central Expressway North
Suite 100 Allen, Texas 75013, USA
Tel: +1-214-547-2400
Fax: +1-214-547-9344

EUROPE

France

Amphenol Socapex S.A.S.
948, Promenade de l'Arve
Bp29, Thyez Cedex
74311, France
Tel: +33-4-5089-2800
Fax: +33-4-5096-1941

United Kingdom

Amphenol Limited
Thanet Way, Whitstable
Kent CT5 3JF, England
Tel: +44-1227-773-200
Fax: 44-1227-276-571

Germany

Amphenol-Air LB GmbH
Am Kleinbahnhof 4
Saarlouis
D-66740, Germany
Tel: 49-6831-9810-00
Fax: 49-6831-9810-30

Italy

Amphenol Military &
Aerospace Operations—
European Sales Operations
Via Barbaiana 5
20020 Lainate
Milano,
Italy+39 02 932 541

Center & East Europe

Amphenol Austria
Wiener Gasse 68
2380 Perchtoldsdorf
Tel: +43-699-10396071
Fax: +43 699 40396071

Amphenol Air-LB

Immeuble Le Doublon
11, Avenue Dobonnet
Courbevoie-Cedex
92407, France
Ph: +33-1-4905-3000
Fax: +33-1-4905-3043

Spain

Amphenol Iberica
Edificio Burgosol Oficina
N 55 C/Comunidad de
Madrid 35 bis -
Las Rozas (Madrid)
Tel: +34-91-6407302
+34-91-6407306
Fax: +34-91-6407307

Holland

Amphenol Benelux
Zadelmaker 121
NL-2401 PD Alphen
aan den Rijn Holland
Tel: +31-172-444903
Fax: +31-172 240254

Sweden

Amphenol
Industrial and Military &
Aerospace
Nordic & Baltic
Military Phone/
Mobile+46702129200
Industrial +46 767909560

ASIA

India

Amphenol Interconnect India Pvt. Ltd.
105 Bhosari Industrial Area
Pune-411026, India
Tel: +9120-6736-0373
Fax: +9120-2712-9158

Japan

Amphenol Japan
471-1, Deba, Ritto City
Shiga 520-3041, Japan
Tel: +81-77-553-8501
Fax: +81-77-551-2200

Singapore

Amphenol East Asia Ltd.
72 Bendemeer Road
03-33 Luzerne
Singapore 339 941
Tel: 65-6294-2128
Fax: 65-6294-3522

China

Amphenol PCD Shenzhen
3/F Building, A4 Songbai
Industrial Park
East Road of Minghuan
Gongming Town, Baon District
Shenzhen, China
Tel: +86-755-8173-8000
Fax: +86-755-8173-8180

Amphenol Interconnect India Pvt. Ltd.

61 Electronics City
Bangalore-560 100, India
Ph: +9180-2852-3838
Fax: +9180-2852-0418

Korea

Amphenol Daeshin Electronics
558 SoSa, SongNae, Bucheon-City
Kyunggi-Do, Korea 420-130
Tel: +82-32-610-3800
Fax: +92-32-673-2507

ROW

Australia

Amphenol Australia Pty Ltd
2 Fiveways Boulevard
Keysborough
VIC 3173
Ph: +61-3-8796-8888
Fax: +61-3-8796-8801

Africa

Amphenol South Africa
30 Impala Road
2196 Sandton-Chistlehurst
South Africa
Tel: +27-11-783-9517
Fax: +27-11-783-9519

Russia

Amphenol Russia
8-2 Yaroslavskaja Str
129164 Moscow, Russia
Tel: +7-495-937-6341
Fax: +7-495-937-6319

Argentina

Amphenol Argentina
Avenida Callao 930
2nd Floor, Office B Plaza
C1023AAP Buenos Aires
Argentina
Tel: 54-11-4815-6886
Fax: 54-11-4814-5779

Israel

Amphenol Bar-Tec Ltd.
www.bar-tec.com
3 Hagavish st
POB 2479 Kfar-Saba 44641
Israel+972-9-7644100

Turkey

Amphenol Turkey & Middle East
Sun Plaza Kat:19
Maslak Mah. Bilim Sok.No:5
34398 Sisli - Istanbul
Tel: +90-212-335-2501
Fax: +90-212-335-2500

Brazil

Amphenol do Brasil Ltda
Rua Diogo Moreira 132
CEP 05423-010
Sao Paulo-SP, Brazil
Tel: +55-11-3815-1003

Amphenol

A Global Company



Pune Operations



Bangalore Operations

Amphenol

Interconnect India Pvt. Ltd.

Manufacturing Locations

Corporate Office & Pune Factory
105, Bhosari Industrial Area, Pune - 411 026.
Tel.: 91-20-6736 0305 / 304
Fax : 91-20-6736 0321

Bangalore Factory
61, Keonics Electronic City, Hosur Road,
Bangalore - 560 100.
Tel.: 91-80-6679 0900 / 910 / 937
Fax.: 91-80-2852 0418
Email : apurvac@amphenol-in.com

Marketing Headquarters
Tel.: 91-20-6736 0305, 6736 0304
Fax : 91-20-6736 0321
Email : svpatil@amphenol-in.com

Western Region
Tel.: 91-20-6736 0334 / 395
Email : sunilp@amphenol-in.com

Northern & Eastern Region
A-421, Pacific Business Park,
Plot No. 37/1, Sahibabad Indst. Area
Site IV, Ghaziabad (UP) - 201 010.
Tel.: 91-120- 4155 781 / 782
Email : sunily@amphenol-in.com

Marketing Locations

Southern Region
No. 1115, 22nd Main Road, 11th Cross,
Sector -1, HSR Layout, Bangalore - 560 102.
Tel.: 91-80-4953 0341 / 345 / 346
Fax: 91-80-4953 8697
Email : kmanoj@amphenol-in.com

Central Region
9/17/A&B, 4th Floor, West Block,
Pinnacle Towers, Road No. 6, IDA Nacharam,
Hyderabad - 500076
Tel.: 91-40-2930 2810
Fax.: 91-40-2930 2811
Email : pprasad@amphenol-in.com

Exports
Tel.: 91-20-6736 0371 / 353
Fax: 91-20-6736 0321
Email : shrikantgramopadhye@amphenol-in.com

www.amphenol-in.com