

Connector Group - L

Straight, 90°

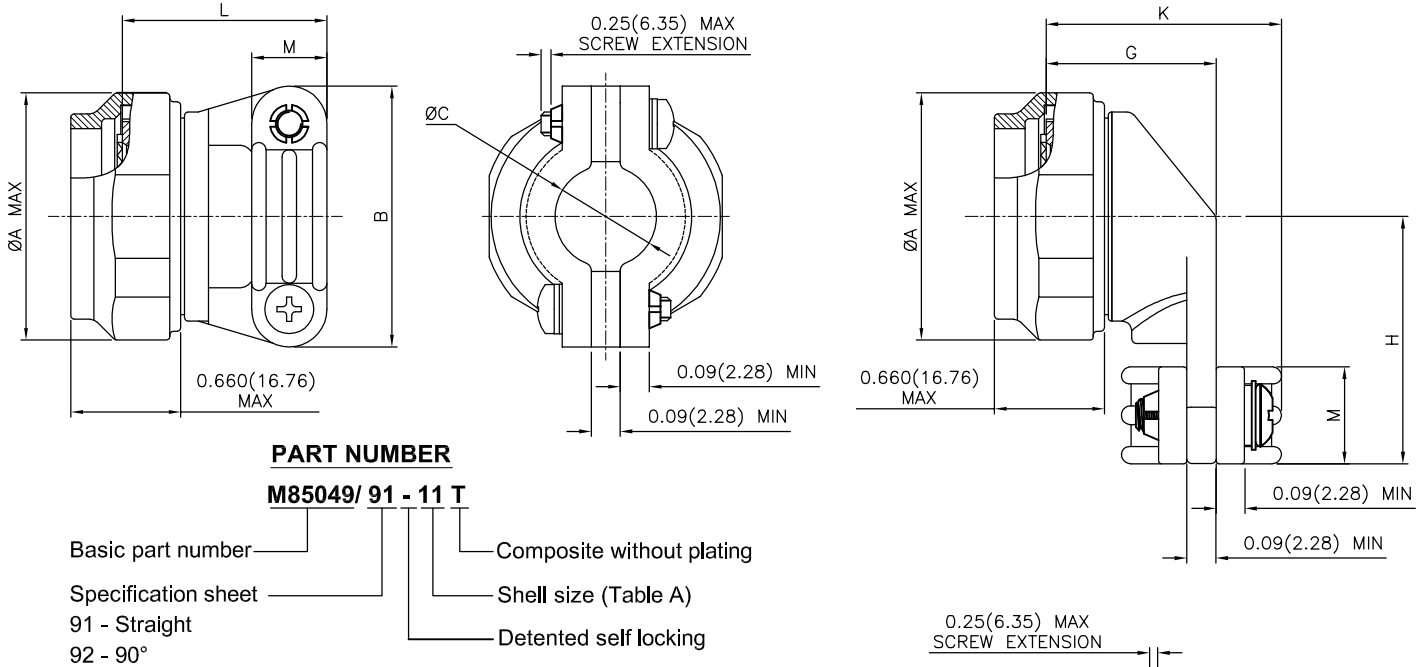

TABLE A

SHELL SIZE	A DIA MAX		B MAX		C DIA ±0.031(0.78)	
	INCH	MM	INCH	MM	INCH	MM
09	0.858	21.79	0.980	24.89	0.219	5.56
11	0.984	24.99	1.050	26.67	0.264	6.71
13	1.157	29.39	1.200	30.48	0.344	8.74
15	1.280	32.51	1.300	33.02	0.460	11.68
17	1.406	35.71	1.420	36.07	0.545	13.84
19	1.516	38.51	1.520	38.61	0.615	15.62
21	1.642	41.71	1.640	41.66	0.698	17.73
23	1.768	44.91	1.770	44.96	0.780	19.81
25	1.890	48.01	1.890	48.01	0.850	21.59

Table continued..

TABLE A

L MAX		H ±0.062(1.57)		K MAX		M ±0.03(0.76)		G MAX		SCREW SIZE
INCH	MM	INCH	MM	INCH	MM	INCH	MM	INCH	MM	
0.840	21.34	0.875	22.23	1.060	26.92	0.375	9.53	0.769	19.53	4-40
0.960	24.38	0.937	23.80	1.100	27.94	0.375	9.53	0.792	20.12	4-40
1.100	27.94	1.031	26.19	1.180	29.97	0.406	10.31	0.847	21.51	6-32
1.100	27.94	1.125	28.58	1.300	33.02	0.406	10.31	0.890	22.61	6-32
1.230	31.24	1.312	33.32	1.380	35.05	0.406	10.31	0.941	23.90	6-32
1.410	35.81	1.375	34.93	1.450	36.83	0.406	10.31	0.972	24.69	6-32
1.510	38.35	1.500	38.10	1.540	39.12	0.406	10.31	1.009	25.63	6-32
1.660	42.16	1.625	41.28	1.620	41.15	0.406	10.31	1.050	26.67	6-32
1.760	44.70	1.750	44.45	1.690	42.93	0.406	10.31	1.085	27.56	6-32

MATERIAL -

Coupling nut, strain relief and strap - Composite in accordance with AS85049

Captivated self-locking telescoping screw and washers - 300 Series corrosion resistant steel / passivated, silver plate optional.

Connector Group - L

Straight, 90°

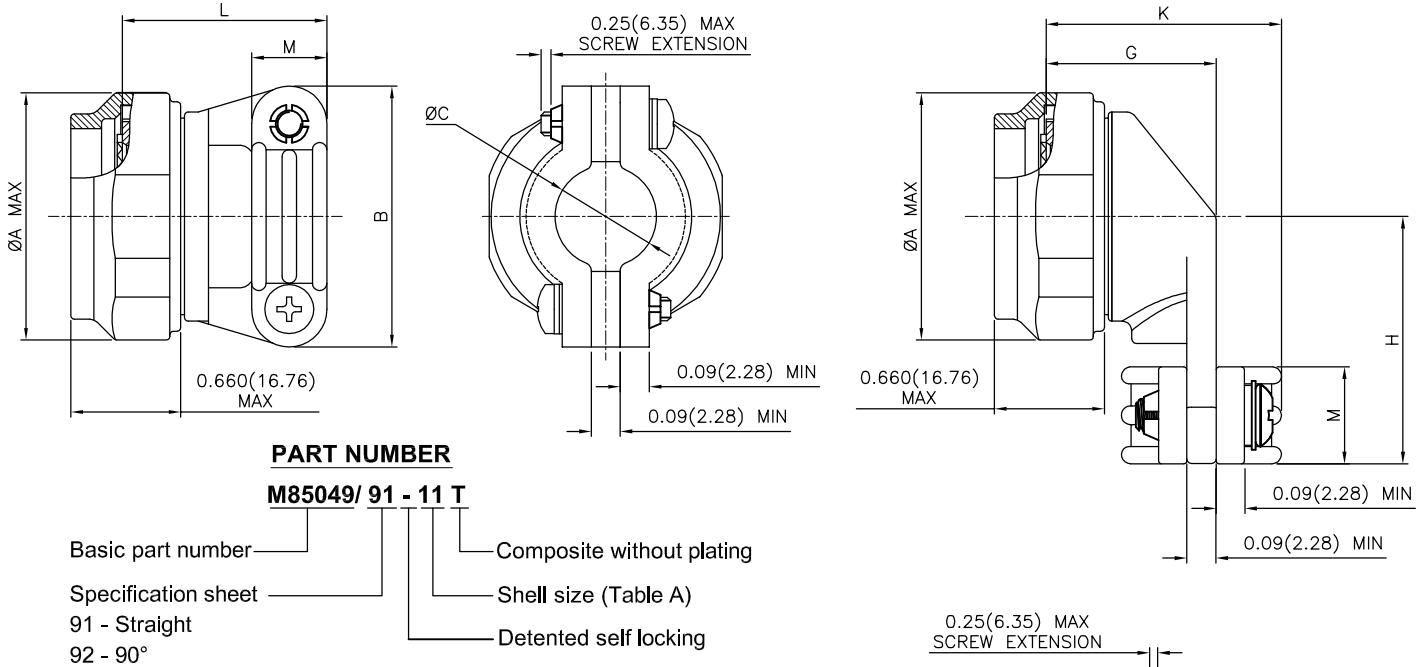

TABLE A

SHELL SIZE	A DIA MAX		B MAX		C DIA ±0.031(0.78)	
	INCH	MM	INCH	MM	INCH	MM
09	0.858	21.79	0.980	24.89	0.219	5.56
11	0.984	24.99	1.050	26.67	0.264	6.71
13	1.157	29.39	1.200	30.48	0.344	8.74
15	1.280	32.51	1.300	33.02	0.460	11.68
17	1.406	35.71	1.420	36.07	0.545	13.84
19	1.516	38.51	1.520	38.61	0.615	15.62
21	1.642	41.71	1.640	41.66	0.698	17.73
23	1.768	44.91	1.770	44.96	0.780	19.81
25	1.890	48.01	1.890	48.01	0.850	21.59

Table continued..

TABLE A

L MAX		H ±0.062(1.57)		K MAX		M ±0.03(0.76)		G MAX		SCREW SIZE
INCH	MM	INCH	MM	INCH	MM	INCH	MM	INCH	MM	
0.840	21.34	0.875	22.23	1.060	26.92	0.375	9.53	0.769	19.53	4-40
0.960	24.38	0.937	23.80	1.100	27.94	0.375	9.53	0.792	20.12	4-40
1.100	27.94	1.031	26.19	1.180	29.97	0.406	10.31	0.847	21.51	6-32
1.100	27.94	1.125	28.58	1.300	33.02	0.406	10.31	0.890	22.61	6-32
1.230	31.24	1.312	33.32	1.380	35.05	0.406	10.31	0.941	23.90	6-32
1.410	35.81	1.375	34.93	1.450	36.83	0.406	10.31	0.972	24.69	6-32
1.510	38.35	1.500	38.10	1.540	39.12	0.406	10.31	1.009	25.63	6-32
1.660	42.16	1.625	41.28	1.620	41.15	0.406	10.31	1.050	26.67	6-32
1.760	44.70	1.750	44.45	1.690	42.93	0.406	10.31	1.085	27.56	6-32

MATERIAL -

Coupling nut, strain relief and strap - Composite in accordance with AS85049

Captivated self-locking telescoping screw and washers - 300 Series corrosion resistant steel / passivated, silver plate optional.

Straight

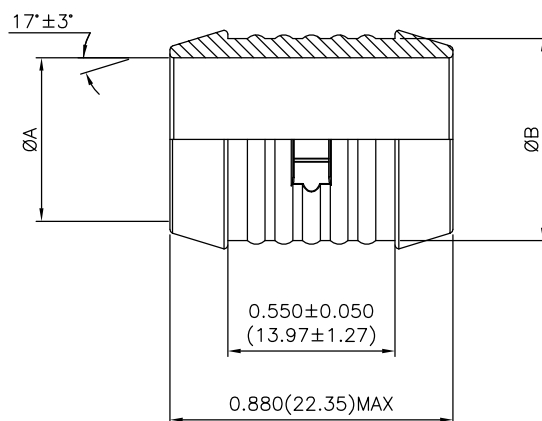

PART NUMBER

M85049/ 93 - 14

Basic part number

Specification sheet

Dash Number (Table A)

TABLE A

DASH NUMBER	A DIA $\pm 0.010(0.254)$		B DIA MAX	
	INCH	MM	INCH	MM
04	0.250	6.35	0.390	9.9
06	0.375	9.53	0.515	13.1
08	0.500	12.70	0.640	16.3
10	0.625	15.88	0.770	19.6
12	0.750	19.05	0.903	22.9
14	0.875	22.23	1.094	27.8
16	1.000	25.40	1.173	29.8
18	1.125	28.58	1.310	33.3
20	1.250	31.75	1.447	36.8
22	1.375	34.93	1.578	40.1
24	1.500	38.10	1.703	43.3
26	1.625	41.28	1.828	46.4
28	1.750	44.45	1.953	49.6

MATERIAL -

Composite in accordance with AS85049

NOTE-

For complete dimensions, see the applicable Military Specification