

# Quad-Channel 160 MSPS 14-bit Analog Input A/D Connector Multimode Fiber Output

ADC-4CH-160M-14-F



## APPLICATIONS

- + Signal Intelligence (SIGINT)
- + Electronic Counter Measures (ECM)
- + Radar and Smart Antenna Arrays
- + Sensors
- + Munitions Guidance
- + Motor Control Feedback
- + Network and Vector Analyzers
- + Microwave Receivers
- + Software Defined Radios
- + Quadrature and Diversity Radio Receivers
- + Digital Satellite Payloads
- + Data Storage

## FEATURES

- + Quad 160 MSPS 14-bit ADCs
- + Onboard programmable sample clock
- + Option for internal or external ADC clock
- + Optional pass through clock for facilitating additions
- + Integrated MIL-DTL-38999
- + Rugged and naturally convection cooled
- + Large range of acceptable supply voltages
- + JESD204B interface
- + MM Fiber Output
- + Compatible with CTF-4G-24TXRX

## BENEFITS

- + Increase PCB space
- + 14 bit resolution
- + Able to synchronize multiple channels/boards
- + Easily interfaces to FPGA-based host board
- + Removes bulky RF cabling
- + Removes costly development
- + Low power consumption
- + TI development board compatibility
- + Extend existing JESD204B via MM Fiber

## OVERVIEW

The ADC-4CH-160M-14-F is a four channel, 160 MSPS, 14-bit analog converter, with an integrated MIL-DTL-38999. The JESD204B I/O devices are to be directly coupled to a host FPGA. The four channel ADC (x2) devices connect through the high bandwidth connector to a FPGA-based host board which maximizes data throughput and minimizes latency.

The ADC-4CH-160M-14-F supports an onboard programmable sample clock generator as well as an external reference input. Multiple ADC-4CH-160M-14-F can be synchronized to increase the number of input channels through the use of trigger input/output signals directly under the control of the FPGA.

## ANALOG INPUT

The ADC-4CH-160M-14-F supports four inputs through 50 Ω MMCX type front panel connectors. The analog inputs are single-ended and are coupled to TI ADL34J45 ADC using a balun and AC coupling capacitor configuration to produce the broadband differential input required by the devices.

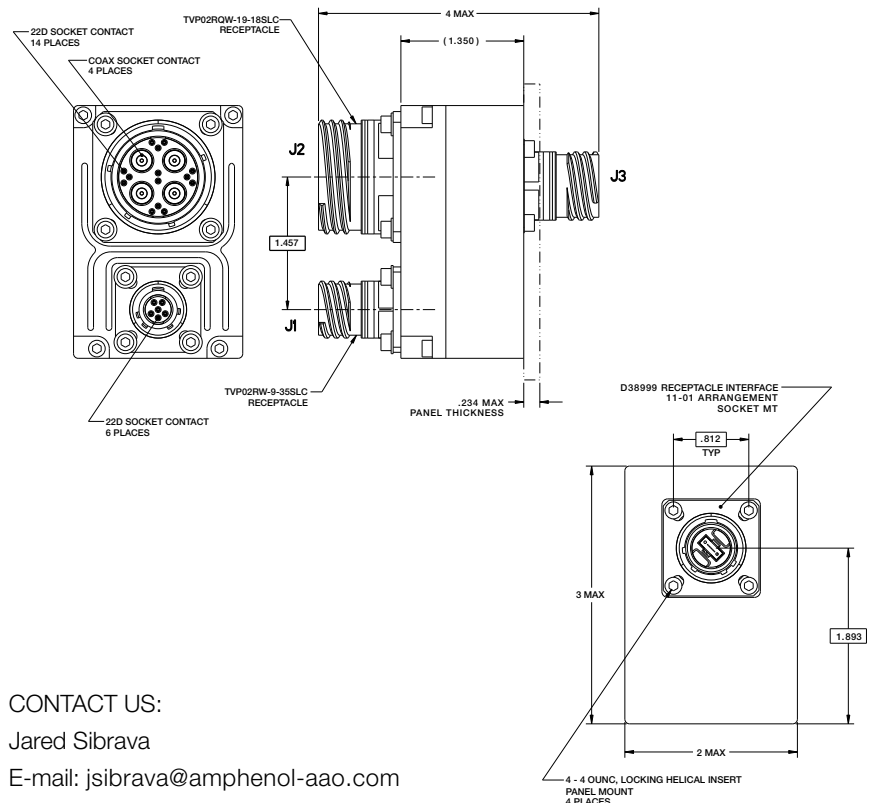

CONTACT US:

Jared Sibrava

E-mail: [jsibrava@amphenol-aao.com](mailto:jsibrava@amphenol-aao.com)

Phone: 607-643-1845

## Analog Input

NUMBER OF CHANNELS	4 single ended
SAMPLING FREQUENCY	Up to 160MSPS
DEVICE	TI ADC34J45
ANALOG BANDWIDTH	Up to 450 MHz
SFDR (AT 70MHz)	86 dBc
SNR (AT 70MHz)	72 dBFS
ENOB (AT 70MHz)	11.7 bits
INPUT IMPEDANCE	50 Ohm, AC coupled
INPUT CONNECTOR	MIL-DTL-38999

## Fiber Interface

NUMBER OF FIBER CHANNELS	4
DEVICE CLOCK	Internal or external triggered
JESD204B SYNCH	External triggered

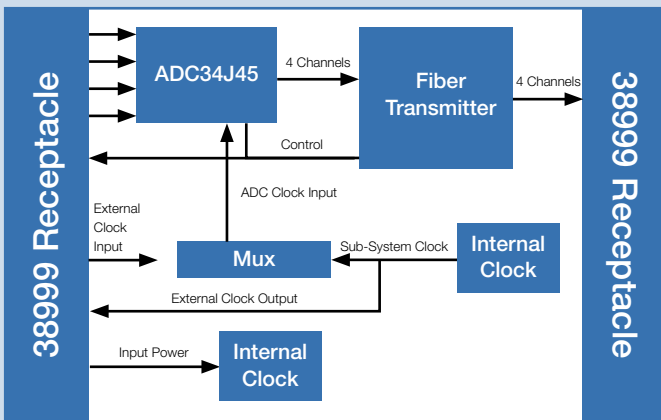

## FIBER OUTPUT

The ADC-4CH-160M-14-F features the new JESD204B connecting to Xilinx, Altera, and other host FPGAs. The multiple advantages of this standard interface makes JESD204B the communication of choice by system engineers. The JESD204B allows for reduction of I/O by serializing the data out and incorporating an embedded clock. It also features a deterministic latency feature enabling the ADC to synchronize to the master clock. The ADC-4CH-160M-14-F utilizes a MM fiber optic transceiver to convert the JESD204B to 1000 Base-SX. This gives the ADC-4CH-160M-14-F the ability to extend its communication up to 220 meters

## CLOCKS, TRIGGERS, & SYNCHRONIZATION

The ADC-4CH-160M-14-F sample clock can be driven from either an external source or onboard programmable sample clock generator. The clock source is controlled by the FPGA. The external front panel clock input is provided through contacts on the 38999 connector.

The external sample clock is a 50Ω LVPECL input designed to operate with an input level between 0 dBm and +8 dBm. The clock input may be sinusoidal or square. -Trigger In- and -Trigger Out- are on the 38999 and Samtec interface. The actual functionality of these signals are dependent on the HDL code in the FPGA of the host carrier card.

## TI INTEGRATION

Amphenol is pleased to offer complete support with our ADC products with the various development support software and hardware from Texas Instruments. Our components, when accompanied with the correct cables, work seamlessly with the Texas Instruments evaluation setup. Systems integrators can reduce system development time with this approach. No new software or maintenance agreements are needed.

**FFT with Dither On**  
( $f_s = 160$  MSPS,  $f_{IN} = 10$  MHz, SNR = 72.5 dBFS, SFDR = 88 dBc)

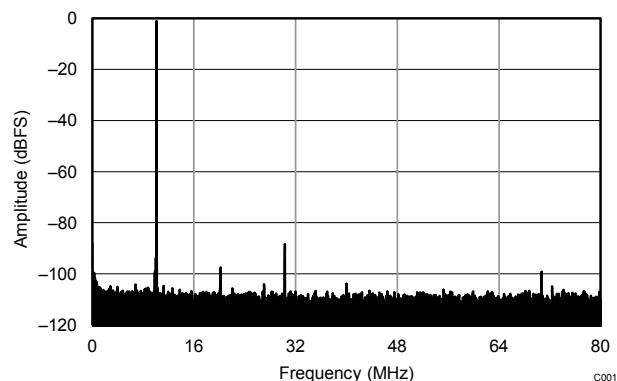

CONTACT US:

Jared Sibrava

E-mail: [jsibrava@amphenol-ao.com](mailto:jsibrava@amphenol-ao.com)

Phone: 607-643-1845

## A/D Fiber Application

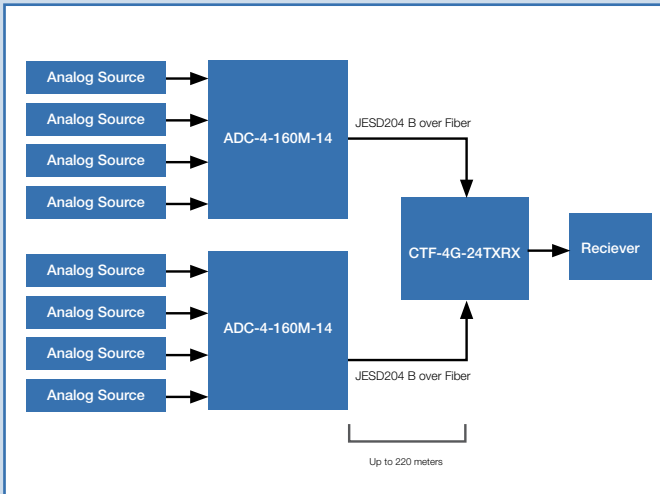

## A/D FIBER APPLICATION

The ADC-4CH-160M-14-F may be connected in tandem with the CTF-4G-24TXRX in order to complete a system. The high density MT connectors can allow conversion from multiple ADC-4CH-160M-14-F-F units. The benefit of this system is ability to extend the JESD204B communication lines.

## REMOTE DIGITAL RECEIVER SYSTEM CONCEPT

Multiple ADC-4CH-160M-14-F may be utilized in the same system to create an extensive network of data processing. All units are able to coexist and operate synchronously. High density MT fiber can be routed in an efficient manner to create a clean system. The following is an example of 10x of ADC-4CH-160M-14-F's on board an aircraft that are being centrally processed.

## Remote Digital Receiver System Concept

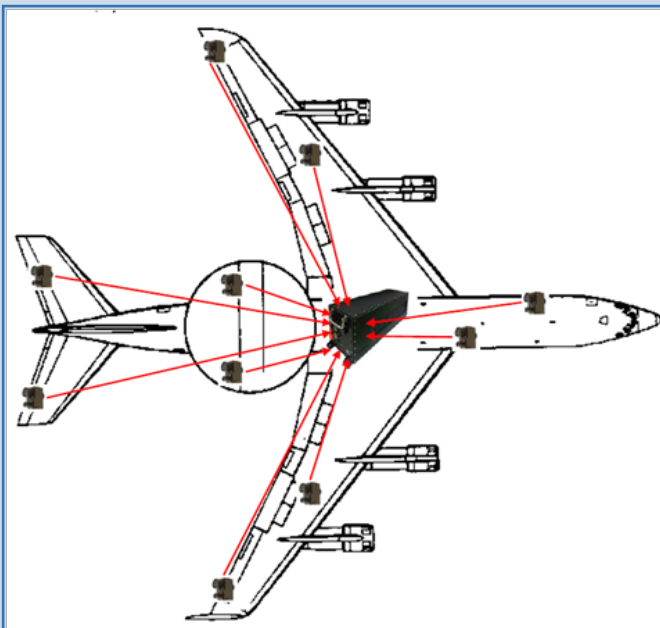

CONTACT US:

Jared Sibrava

E-mail: [jsibrava@amphenol-ao.com](mailto:jsibrava@amphenol-ao.com)

Phone: 607-643-1845

## Overview

Amphenol integrated electronic products are designed and manufactured to our Ruggedization guidelines listed below. These guidelines ensure years of reliable operation in harsh environment applications where extreme operating temperatures, shock, vibration and corrosive atmospheres are regularly experienced

## Temperature

- Operating Temperature - Thermal Cycles between -40°C and 85°C while device is operating
- Temperature is measured at chassis housing or card edge
- Storage Temperature - Thermal Cycles between -55°C and 125°C

## Humidity

- Operating Humidity – Humidity cycle between 0-100% non-condensing humidity while device is operating
- Storage Humidity – Humidity cycle between 0-100% condensing humidity

## Sealing

- Sealing can be optionally provided at the MIL-DTL-38999 interface with up to 10-5 cc/sec performance

## Fluids Susceptibility

- MIL-DTL-38999 receptacle interface per EIA-364-10E

## Vibration & Shock

- Sine Vibration – 10 g Peak, 5-2,000Hz
  - Based on a sine sweep duration of 10 minutes per axis in each of three mutually perpendicular axes. May be displacement limited from 5 to 44 Hz, depending on specific test.
- Random Vibration - 0.005@5Hz, 0.1@15Hz, 0.1@2,000Hz
  - 60 minutes per axis, in each of three mutually perpendicular axes.
- 40 G Peak Shock Cycle
  - Three hits in each axis, both directions, ½ sine and terminal-peak saw tooth, Total 36 hits.

## Altitude

- -1,500 to 60,000 ft Altitude Testing w/ Rapid Depressurization

## Electromagnetic Compatibility

- Designed to comply with MIL-STD-461E

## Printed Circuit Board Assemblies

- Conformal Coat
  - Amphenol performs Conformal Coating to both sides of printed circuit board assemblies using HUMISEAL IB31 in accordance with IPC-610, Class 3.
- Printed Circuit Board Rigidity
  - Amphenol printed circuit boards are fabricated in accordance with IPC-6012, Class 3.
- Printed Circuit Board Fabrication
  - Amphenol printed circuit boards acceptance criteria is in accordance with IPC-610, Class 3.

## Reliability Predictions (MTBF)

Amphenol can perform Mean Time Between Failure (MTBF) reliability analysis in full compliance with MIL-HDBK-217F-1 Parts Count Prediction and MIL-HDBK-217F-1 Parts Stress Analysis Prediction. We can also perform reliability analyses in full compliance of ANSI/VITA 51.1 if it is required or preferred over the later method.

## CONTACT US:

Jared Sibrava

E-mail: [jsibrava@amphenol-aa.com](mailto:jsibrava@amphenol-aa.com)

Phone: 607-643-1845

**Notice:** Specifications are subject to change without notice. Contact your nearest Amphenol Corporation Sales Office for the latest specifications. All statements, information and data given herein are believed to be accurate and reliable but are presented without guarantee, warranty, or responsibility of any kind, expressed or implied. Statements or suggestions concerning possible use of our products are made without representation or warranty that any such use is free of patent infringement and are not recommendations to infringe any patent. The user should assume that all safety measures are indicated or that other measures may not be required. Specifications are typical and may not apply to all connectors.

AMPHENOL is a registered trademark of Amphenol Corporation. ©2015 Amphenol Corporation REV:3/09/2015