

RUGGED USB & DVI EXTENDER

AMPHENOL HIGH SPEED SOLUTIONS FOR KVM

PDS-284



DESCRIPTION

Amphenol High Speed Solutions is pleased to introduce the industry's first Rugged USB and DVI extender hardware set (KVM-Key, Mouse and Video) designed to extend the interfaces. The integrated set contains a transmitter module, receiver module, and two mating cables for 1000+ foot extension of four channels of USB 2.0 and two channels of single link digital DVI with the highest resolutions. The DVI and USB channels are converted to single mode fiber for the extension in length. The solutions are powered by 28 Volts and meant for stand-alone integration.

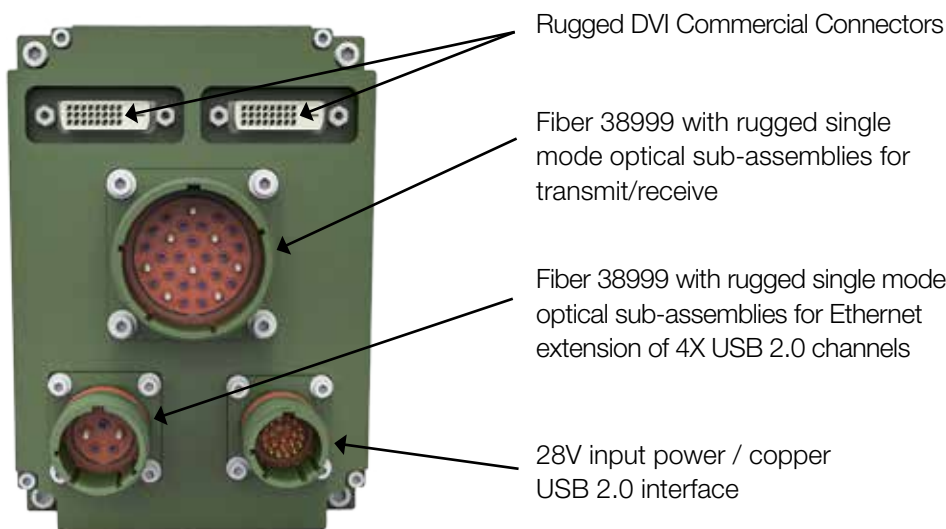

PART NUMBERS

CF-020010-906 - Host Side Component

- Transmits 2 channels DVI over single mode fiber
- Connects 1 channel of USB 2.0 to the host computer

CF-020010-909 - Device Side Component

- Receives DVI over single mode fiber
- Connects 4 channels of USB 2.0 to the devices and sends over fiber

CF-901201-731

- 100 ft Fiber Ethernet Cable between the Host and Device

CF-901201-022R

- 100 ft Fiber Cable between the Host and Device

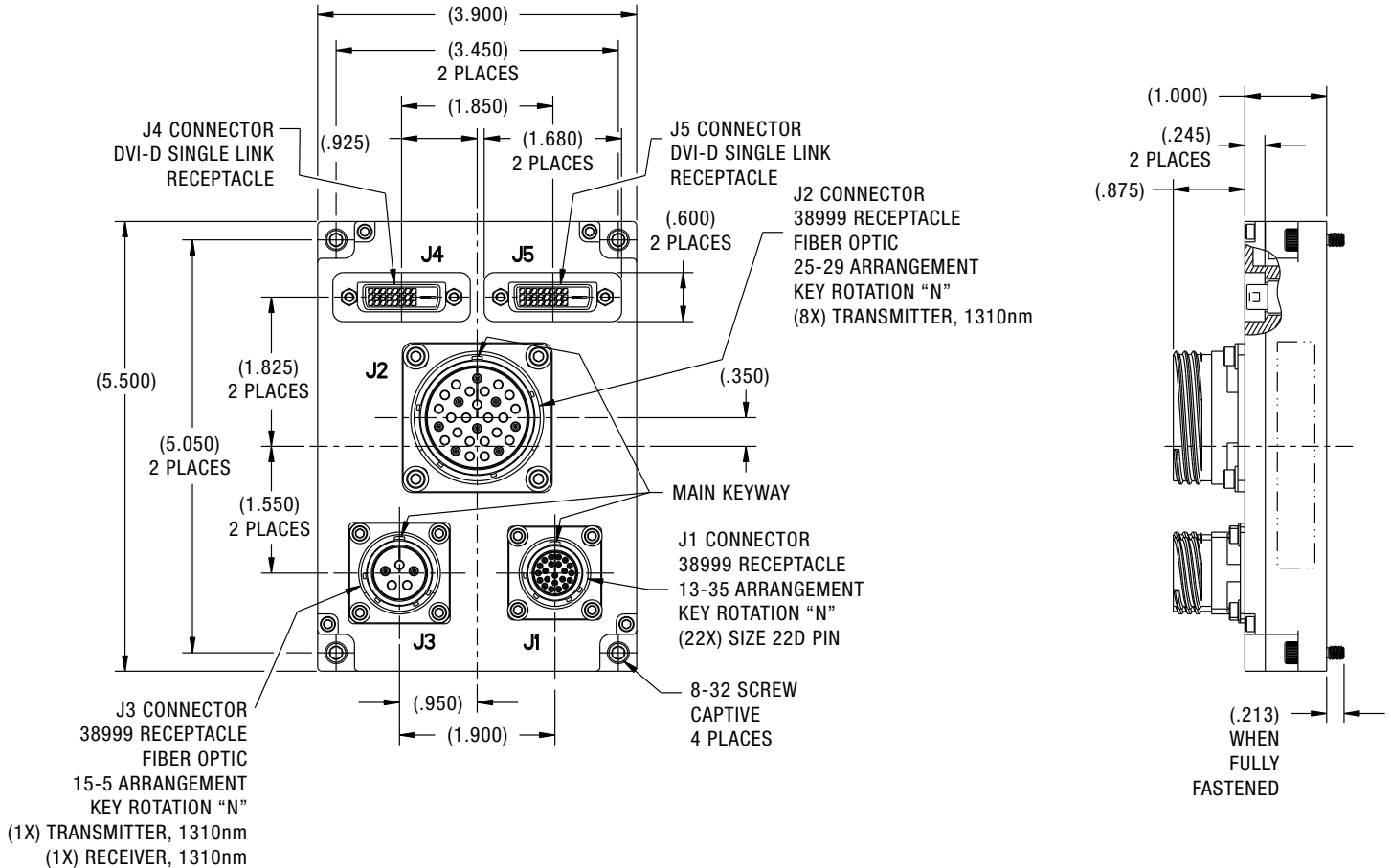

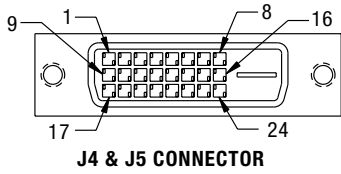
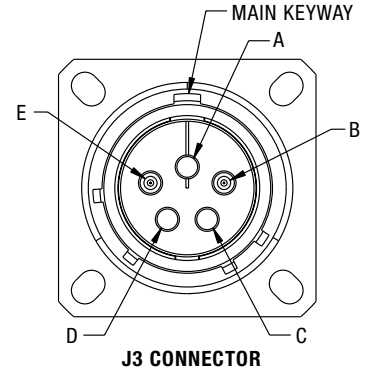
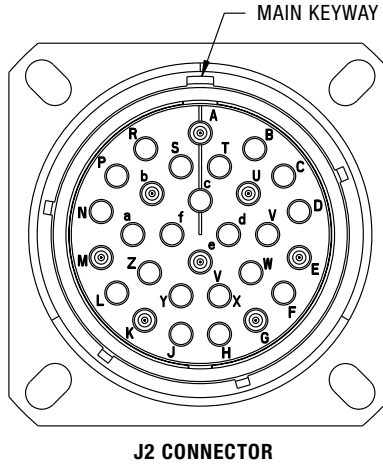
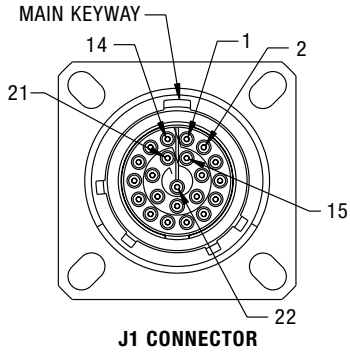

Connector Designator	Ref Connector Part Number	Ref Mating Connector P/N
J1	TVP00RGW-13-35PL	TV06RGW-13-35-SL
J2	CF-971189-29N	CF-523625-29SL
J3	CF-971184-05N	CF-523615-05SL
J4	74320-5004	Standard DVI-D
J5	(DVI-D, SOCKET)	(SINGLE LINK, PIN)

DEVICE SIDE

Block Diagram :

CF-020010-909 BLOCK DIAGRAM RECEIVER

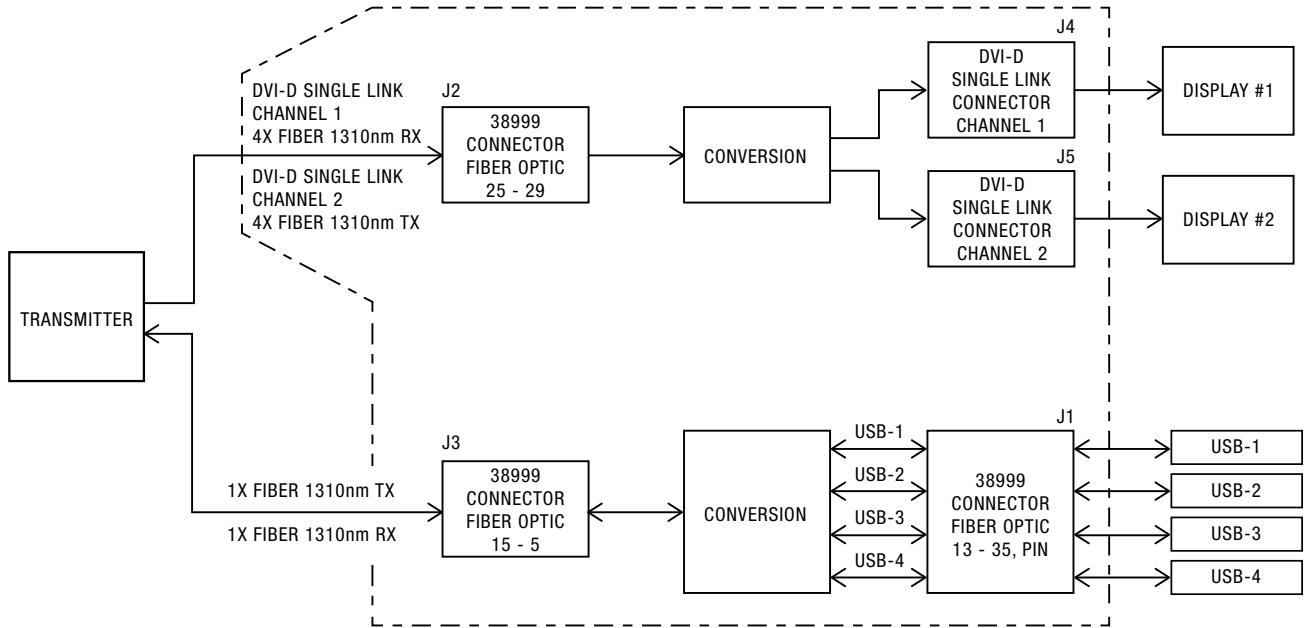

Pinout :

J1 I/O Chart	
Pin ID	Signal Info
1	USB1+
2	USB1-
3	N/C
4	N/C
5	N/C
6	N/C
7	N/C
8	N/C
9	N/C
10	Power
11	Power
12	GND
13	GND
14	N/C
15	USB1 Shield
16	N/C
17	N/C
18	N/C
19	N/C
20	N/C

21	N/C
22	N/C

J2 I/O Chart	
Pin ID	Signal Info
A	DVI Channel 1 Transmit
E	
G	
U	
K	DVI Channel 2 Transmit
M	
b	
e	

J3 I/O Chart	
Pin ID	Signal Info
A	N/C
B	TX (1310nm)
C	N/C
D	N/C
E	RX (1310nm)

J4 and J5 I/O Chart	
Pin ID	Signal Info
1	TMDS Data2-
2	TMDS Data2+
3	TMDS Data2 Shield
4	N/C
5	N/C
6	N/C
7	N/C
8	N/C
9	TMDS DATA1-
10	TMDS DATA1+
11	TMDS DATA1 Shield
12	N/C
13	N/C
14	N/C
15	N/C
16	N/C
17	TMDS DATA0-
18	TMDS DATA0+
19	TMDS DATA0 Shield
20	N/C

21	N/C
22	TMDS Clock Shield
23	TMDS Clock +
24	TMDS Clock -

Block Diagram :

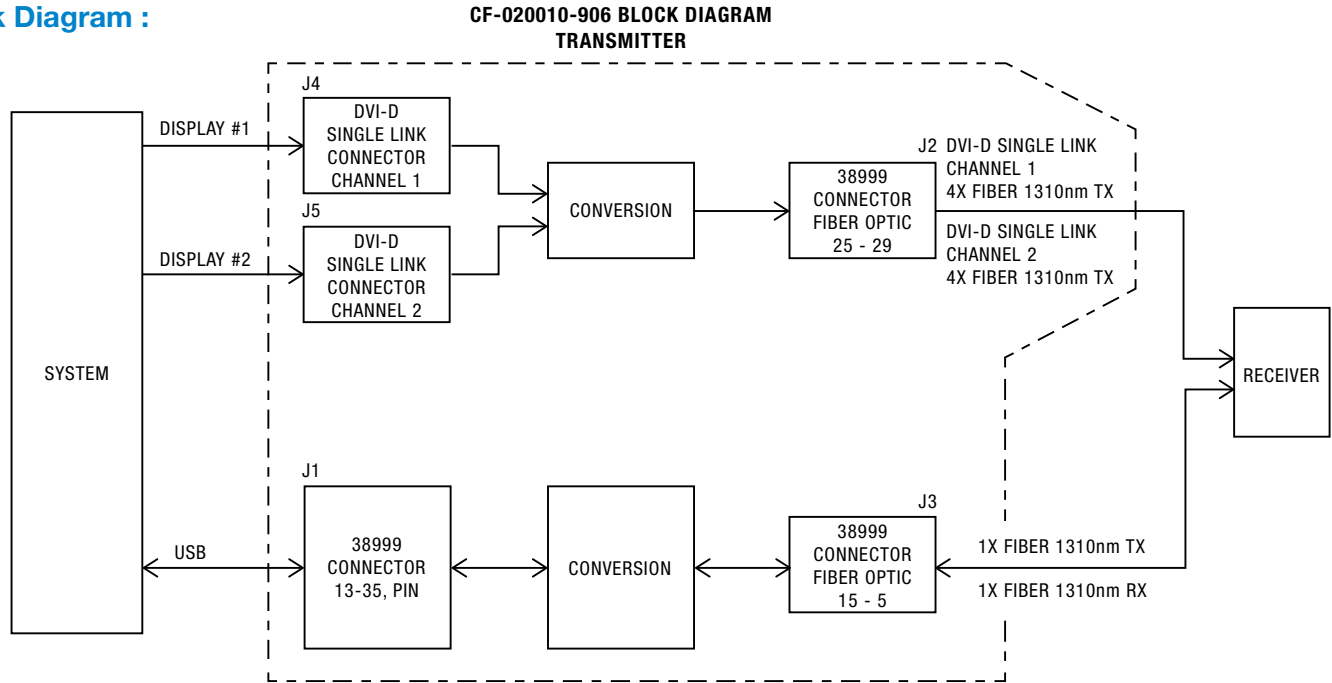

Pinout :

J1 I/O Chart	
Pin ID	Signal Info
1	USB1+
2	USB1-
3	USB2+
4	USB2 Shield
5	USB3+
6	USB3-
7	USB4+
8	USB4-
9	N/C
10	Power
11	Power
12	GND
13	GND
14	N/C
15	USB1 Shield
16	USB2-
17	USB3 Shield
18	USB4 Shield
19	N/C
20	N/C

21	N/C
22	N/C

J2 I/O Chart	
Pin ID	Signal Info
A	DVI Channel 1 Receive
E	
G	
U	
K	DVI Channel 2 Receive
M	
b	
e	

J3 I/O Chart	
Pin ID	Signal Info
A	N/C
B	TX (1310nm)
C	N/C
D	N/C
E	RX (1310nm)

J4 and J5 I/O Chart	
Pin ID	Signal Info
1	TMDS Data2-
2	TMDS Data2+
3	TMDS Data2 Shield
4	N/C
5	N/C
6	N/C
7	N/C
8	N/C
9	TMDS DATA1-
10	TMDS DATA1+
11	TMDS DATA1 Shield
12	N/C
13	N/C
14	N/C
15	N/C
16	N/C
17	TMDS DATA0-
18	TMDS DATA0+
19	TMDS DATA0 Shield
20	N/C

21	N/C
22	TMDS Clock Shield
23	TMDS Clock +
24	TMDS Clock -

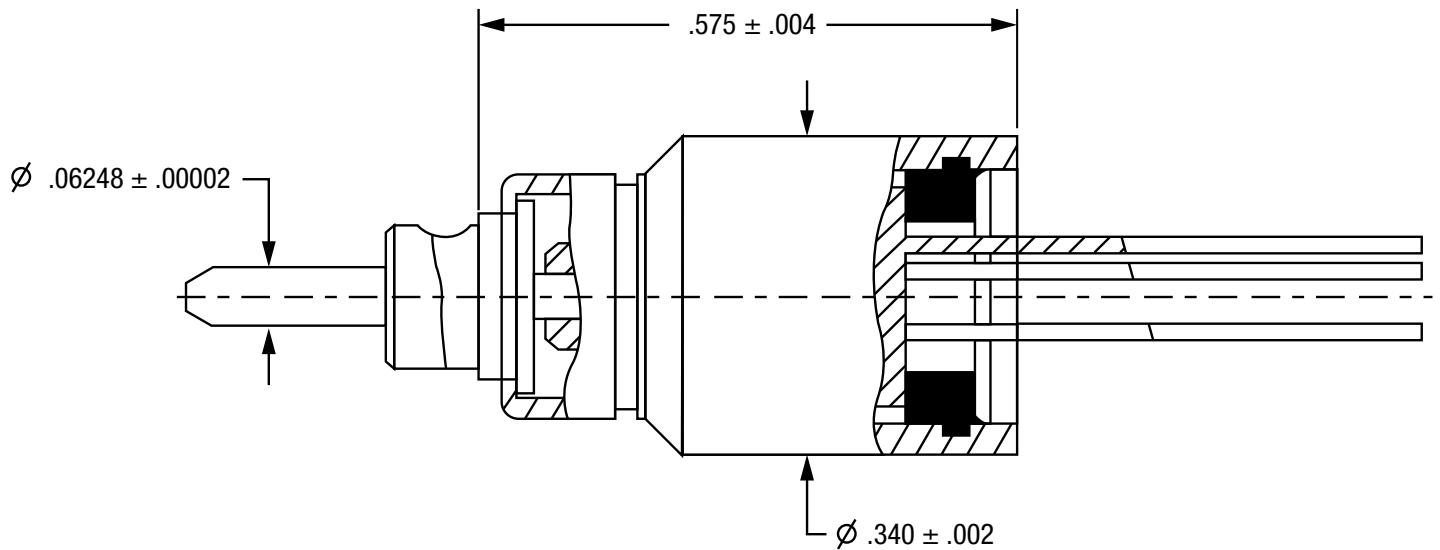

Optical Parameters		
	MIN	MAX
Optical Output Power	-11dBm	-3dBm
Optical Rise/Fall Time	-	260ps
Optical Sensitivity	-23dBm	-3dBm

Power	28 DC power interface; 5 Watts Max
Copper USB	Fully compliant USB 2.0 interfaces for device and host side with signaling to devices/host as well as 5V/GND interfaces
Ethernet Fiber Connectivity	1 transmitter; 1 receiver 1310nm single mode transmitter/receiver Min power output -11dBm; Max receiver sensitivity -20dBm
DVI Copper Connectivity	2 inputs (host side) or 2 outputs (device side) Standard DVI-D single link interfaces
DVI Fiber Connectivity	8 transmitters (host side) or 8 receivers (device side) 1310nm single mode transmitter/receiver Min power output -11dBm; Max receiver sensitivity -20dBm

TECH SPECS

Temperature

- Operating Temperature - Thermal Cycles between -40°C and 85°C while device is operating
- Temperature is measured at chassis housing or card edge
- Storage Temperature - Thermal Cycles between -55°C and 125°C

Humidity

- Operating Humidity – Humidity cycle between 0-100% non-condensing humidity while device is operating
- Storage Humidity – Humidity cycle between 0-100% condensing humidity

Sealing

- Sealing can be optionally provided at the MIL-DTL-38999 interface with up to 10⁻⁵ cc/sec performance

Fluids Susceptibility

- MIL-DTL-38999 receptacle interface per EIA-364-10E

Vibration & Shock

- Sine Vibration – 10 g Peak, 5-2,000Hz
 - Based on a sine sweep duration of 10 minutes per axis in each of three mutually perpendicular axes. May be displacement limited from 5 to 44 Hz, depending on specific test.
- Random Vibration - 0.005@5Hz, 0.1@15Hz, 0.1@2,000Hz
 - 60 minutes per axis, in each of three mutually perpendicular axes.
- 40 G Peak Shock Cycle
 - Three hits in each axis, both directions, ½ sine and terminal-peak saw tooth, Total 36 hits.

Altitude

- -1,500 to 60,000 ft Altitude Testing w/ Rapid Depressurization

Electromagnetic Compatibility

- Designed to comply with MIL-STD-461E

Printed Circuit Board Assemblies

- Conformal Coat
 - Amphenol performs Conformal Coating to both sides of printed circuit board assemblies using HUMISEAL IB31 in accordance with IPC-610, Class 3.
- Printed Circuit Board Rigidity
 - Amphenol printed circuit boards are fabricated in accordance with IPC-6012, Class 3.
- Printed Circuit Board Fabrication
 - Amphenol printed circuit boards acceptance criteria is in accordance with IPC-610, Class 3.

Reliability Predictions (MTBF)

Amphenol can perform Mean Time Between Failure (MTBF) reliability analysis in full compliance with MIL-HDBK-217F-1 Parts Count Prediction and MIL-HDBK-217F-1 Parts Stress Analysis Prediction. We can also perform reliability analyses in full compliance of ANSI/VITA 51.1 if it is required or preferred over the later method.

Notice: Specifications are subject to change without notice. Contact your nearest Amphenol Corporation Sales Office for the latest specifications. All statements, information and data given herein are believed to be accurate and reliable but are presented without guarantee, warranty, or responsibility of any kind, expressed or implied. Statements or suggestions concerning possible use of our products are made without representation or warranty that any such use is free of patent infringement and are not recommendations to infringe any patent. The user should assume that all safety measures are indicated or that other measures may not be required. Specifications are typical and may not apply to all connectors.

AMPHENOL is a registered trademark of Amphenol Corporation. ©2016 Amphenol Corporation REV:12/2/2016