

Amphenol



Amphenol

SERIES PUSH PULL
CONNECTORS
REF. MIL - C - 81703



Amphenol Interconnect India Pvt. Ltd. manufacturers of India's largest range of connection, is a subsidiary of Amphenol Corporation, USA. Technical and financial support from Amphenol Corp. one of the largest connector manufacturers in the world, back the production of more than 885 varieties of connectors at Amphenol. With over two decades of experience in the manufacture and development of professional grade connectors. Amphenol is supported by infrastructure that includes an in-house R&D facility employing state of the art computer aided designing and a full fledged tool room. The production facility has the latest manufacturing technology and stringent quality control check ensure reliability.

We have excellent infrastructure to design and manufacture high performance Space Grade Circular/PC/ Rectangular Rack & Panel Connectors like modern sophisticated computerized numerically controlled machines, a well equipped tool room, modernized Quality control laboratory and sophisticated CAD/IDEAS/PRO-E design facility etc. Our Engineers are well trained in Amphenol facilities for design of connectors. We are confident with our experience & exposure of over 30 years in the connector technology and our proven success in the development of space grade connectors.

PUSH PULL CONNECTORS:

The Amphenol PTDS Series Push Pull Connectors are developed for Aerospace applications the stage separation of satellites and missiles. The PTDS is with unique locking system which ensure full proof mating and protection. These features allow unmanned disconnection of discarded stages, which proves to be mission critical in nature. The Amphenol PTDS series connectors are also qualified by Indian Space Agency to specifications ELG/INDG/TF/DBAS/01/97 and used successfully in many major Indian programs.

Page Contents

Introduction	1
Straight Plug/Rec	2
Lanyard Straight Plug/Rec	3
Receptacle/Orientation	4
Technical Data	5
Insert Configuration	6
Ordering Information	7
Accessories	8

S TRAIGHT PLUG (PTDS76)

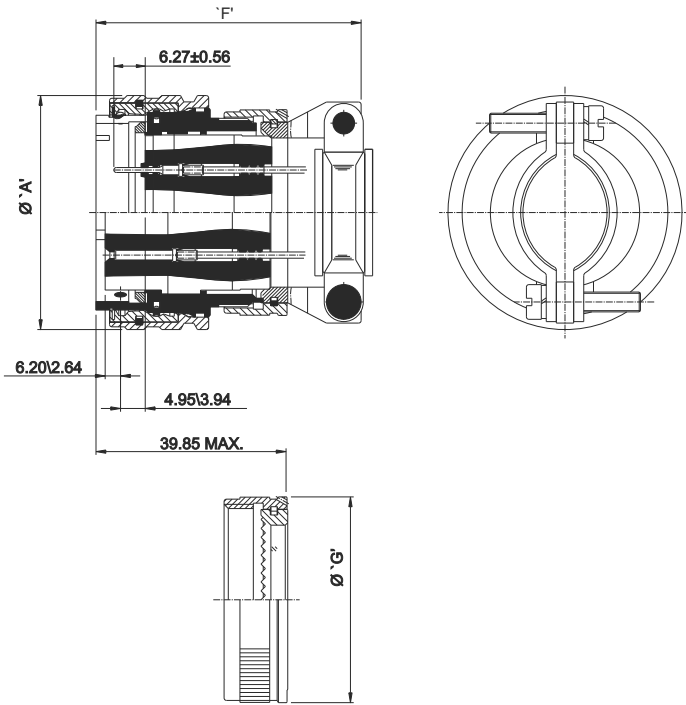

Shell Size		A	F	G
MIL	A11L	max	max	max
03	10	20.40	48.74	17.00
07	12	23.70		21.80
12	14	26.90	54.71	25.00
19	16	31.50		28.25
27	18	36.10		30.95
37	20	39.30		34.15
61	24	47.30		42.00

*Ref. Ordering information page 7

WALL MOUNTING RECEPTACLE (PTDS70)

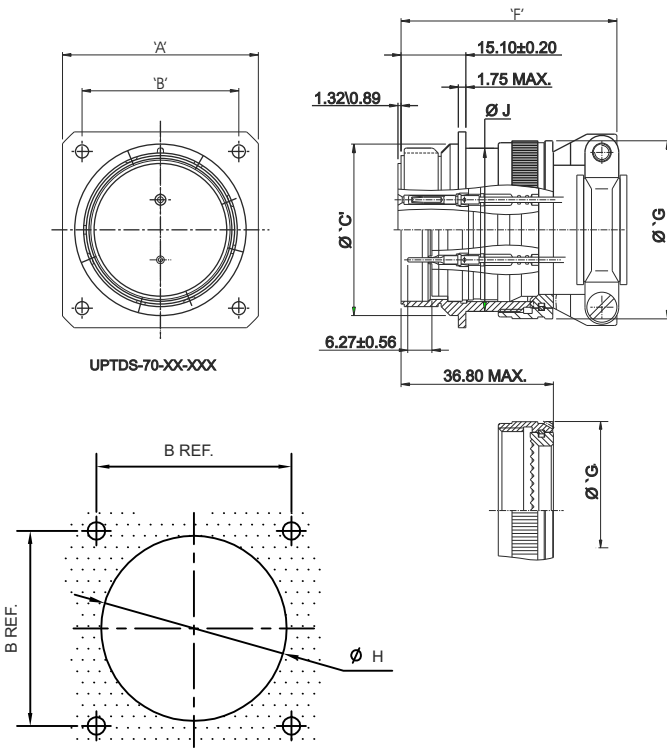

(SHELL REAR SIDE OD.)

Shell Size	A11L	A max	B ±0.10	C max	F max	G max	H ±0.08	J ±0.03
03	10	22.60	15.90	14.50	45.77	17.00	14.81	-
07	12	25.80	18.26	17.35		21.80	19.30	19.02
12	14	28.20	20.62	20.80	51.73	25.00	22.48	22.19
19	16	30.60	23.02	24.00		28.25	25.65	-
27	18	33.00	24.60	28.70		30.95	28.98	26.95
37	20	36.90	29.36	32.00		34.15	32.28	30.16
61	24	45.70	36.53	39.90		42.00	40.21	38.06

Panel Cut Out for Front or Rear Mount

*Ref. Ordering information page 7

L ANYARD STRAIGHT PLUG (PTDS78)

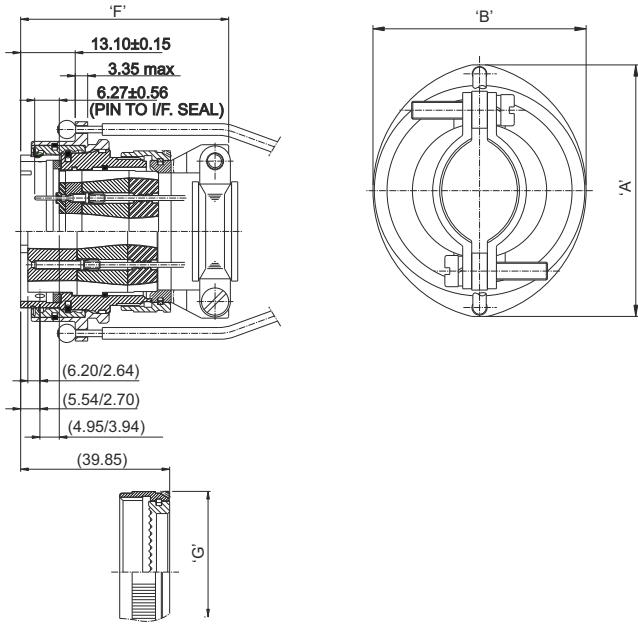

Shell Size	A	B	F	G
MIL	A _{ILL}	max	max	max
3	10	32.35	23.30	17.00
7	12	36.15	26.80	48.74
12	14	39.20	29.60	25.00
19	16	43.00	33.55	28.25
27	18	46.70	37.20	54.71
37	20	48.95	40.70	30.95
61	24	57.10	47.85	34.15
				42.00

*Ref. Ordering information page 7

JAM NUT TYPE RECEPTACLE (PTDS74)

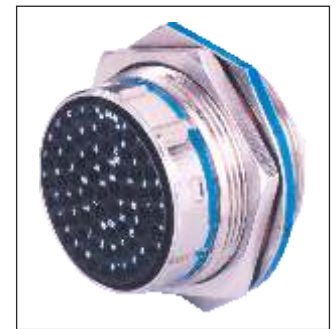
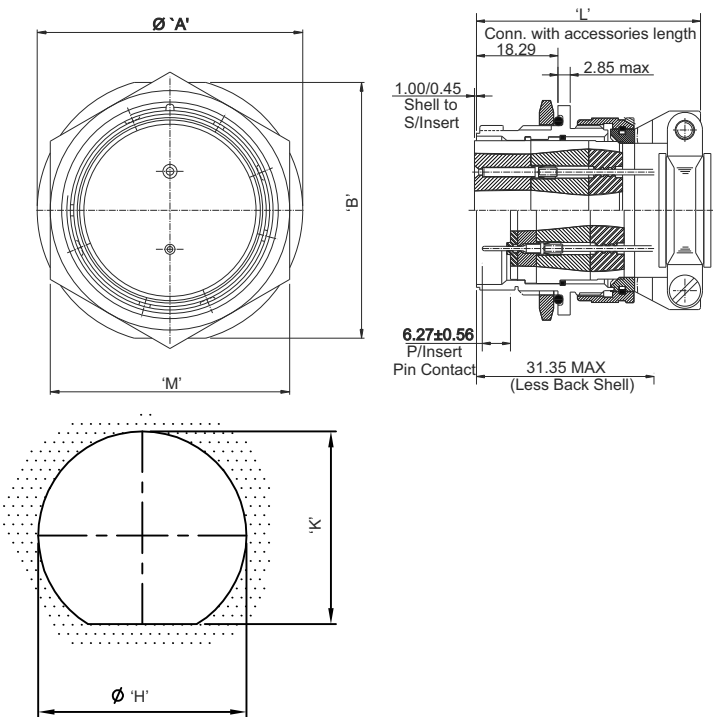

Shell Size	A	B	H	K	L	M
	max	max	$\begin{matrix} +0.20 \\ -0 \end{matrix}$	$\begin{matrix} +0.10 \\ -0 \end{matrix}$	max	Max
03	19.20	19.20	14.40	13.56		16.31
07	22.40	22.40	17.55	16.79	44.80	21.07
12	27.20	27.20	20.73	19.91		24.24
19	30.40	29.60	25.48	24.61		27.40
27	33.60	33.50	28.65	27.81	50.80	32.18
37	38.30	36.30	31.83	30.99		35.36
61	47.80	47.20	38.20	37.26		43.02

Panel Cut Out

*Not yet developed. Contact factory for further details.

*Ref. Ordering information page 7

12-8

Recept. with normal Orientation

Recept. with with Pin & Socket Insert (150° 'B' ORIENT.)

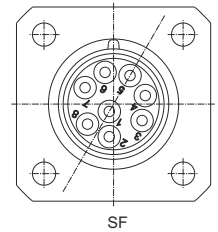
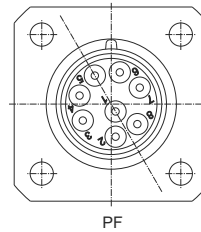
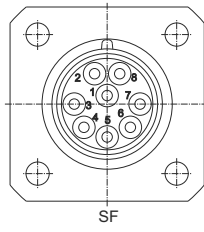
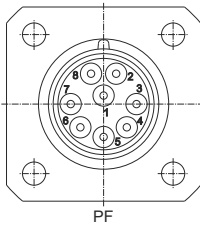

14-19

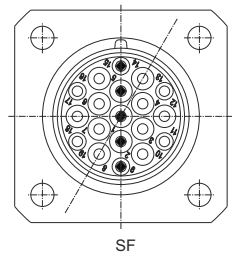
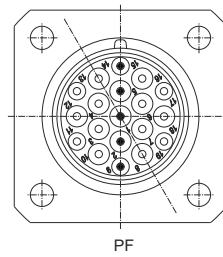
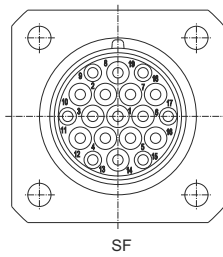
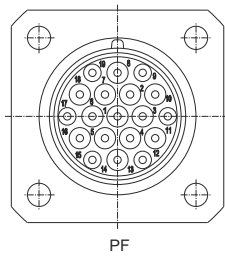

18-32

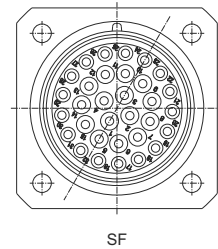
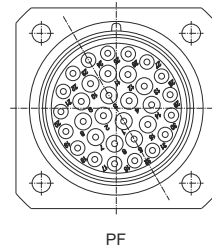
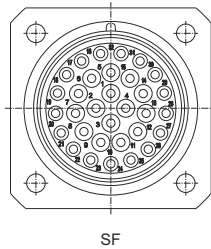
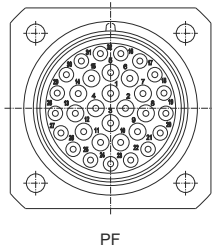

24-61

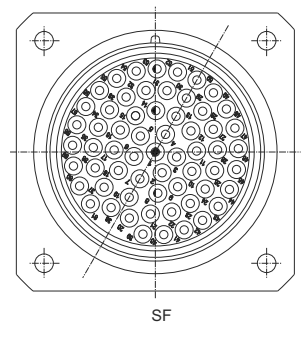
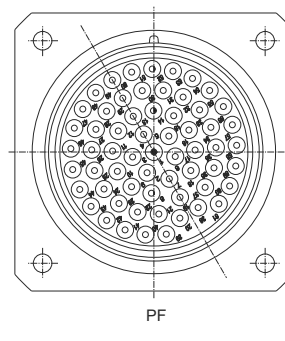
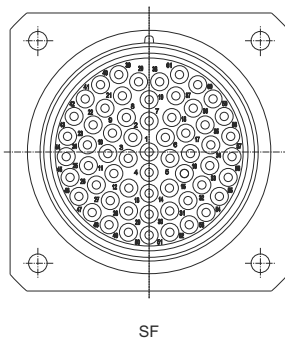
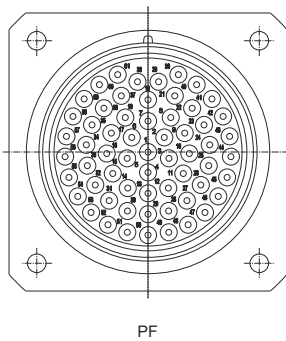

1. Operating Voltage	: Service rating	Voltage
	I	600V RMS
	II	1000V RMS
2. Operating Current	: Contact Size	Current in AMPH
	20	7.5
	16	13.0
3. Operating Temperature	-55 to + 200° C	
4. Materials		
a) Shell	: Aluminum Alloy	
b) Insulator	: High Grade Plastic	
c) Contact	: Copper Alloy	
d) Grommet & Seal	: Silicon Based Elastomer	
5. Finish		
a) Contact	: 1.27 micron Gold plating over nickel	
b) Shell & C/Ring & Accessory	: Electroless Nickel plating	
6. Contact resistance	: Contact Size	CR in milliohms max.
	20	7.3
	16	3.9
7. Insulation resistance	: 10000 Megaohms	
8. Voltage Proof	: 0.8 KV M	
9. Voltage Proof	: Service Rating	Voltage
	I	1500V RMS
Coupling Force Axial - Pounds (Kgs)	II	2300V RMS

Shell Size		Max. Engagement & Disengagement force as per SAE AS81703	Min. Disengagement force as per SAE AS81703	Recommended by VSCC. in (Kgs) Space Application
MIL	AILL			
* 3	10			
7	12	20 (9.07)	1.50 (0.680)	(4.0 - 7.0)
12	14	34 (15.42)	2.00 (0.907)	(4.5 - 8.0)
*19	16			
27	18	40 (18.14)	4.00 (1.814)	(5.0 - 9.0)
*37	20			
61	24	49 (22.24)	7.00 (3.175)	(5.5 - 11.00)

*Not in Amphenol Range

10. Applicable Tools

a) Crimping Tools	M22520/ 1-01
b) Locator	M22520/ 1-01
c) I/R Tool	a) M 81969/14-11 (20 size) b) M 81969/14-03 (16 size)

11. Ref. Std./Spec

MIL-C-81703

VSSC SPEC. ELG/INDG/TF/DBAS/01/97

Insert Configuration

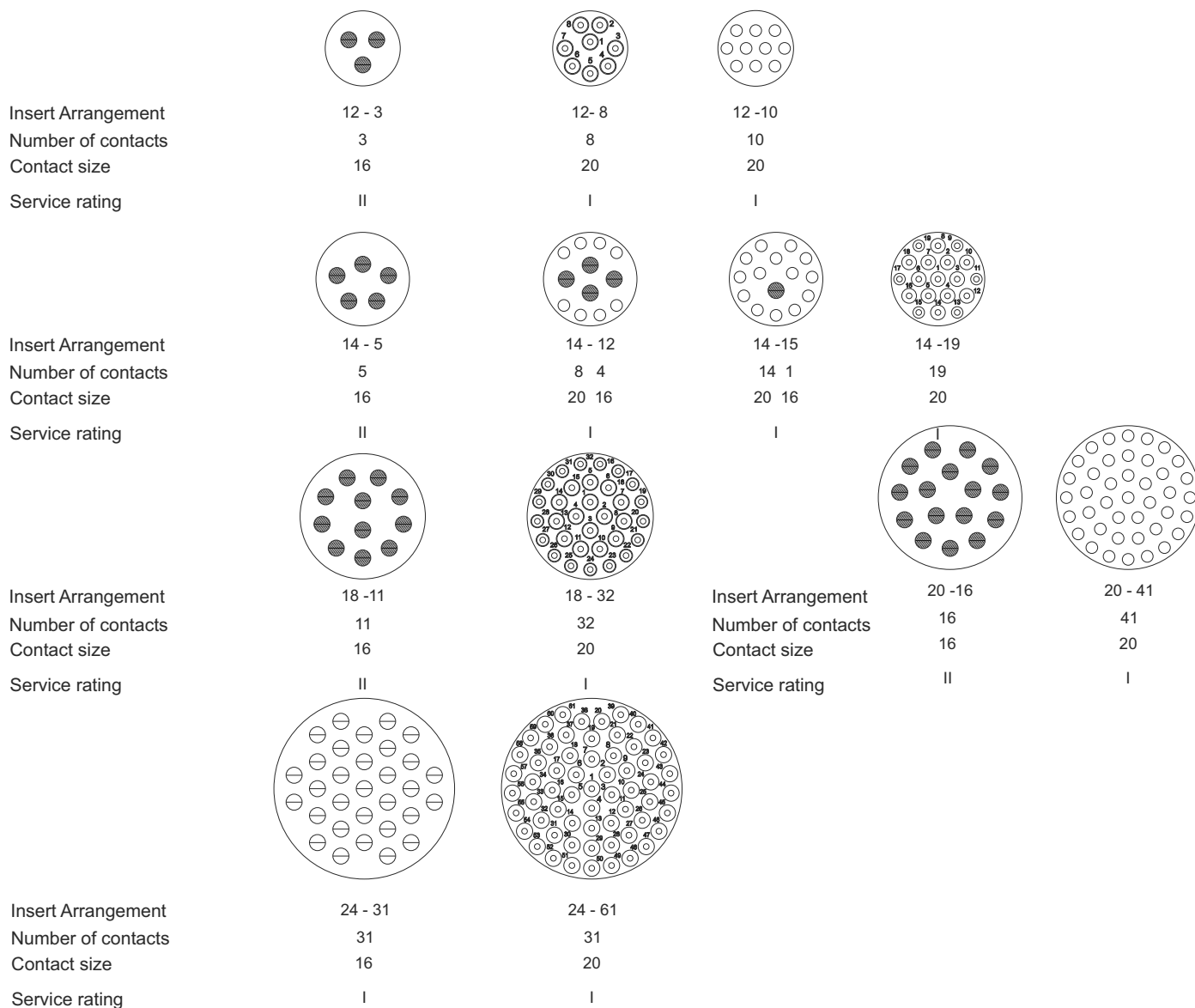

MIL-C 81703 S/Size	Amphenol Insert Configuration	W	X	Y	Z	B	C	# 20	# 16
7-0	12-3	-	-	180	-	-	-	-	03
	12-8	90	112	203	292	150	-	08	-
	12-10	60	155	270	295	-	-	10	-
12-0	14-5	40	92	184	273	-	-	-	05
	14-12	43	90	-	-	-	-	08	04
	14-15	30	165	315	-	-	-	14	01
	14-19	30	165	315	-	150	-	19	-
27-0	18-11	62	119	241	340	150	-	-	11
	18-32	85	138	222	265	150	-	32	-
37-0	20-16	238	318	333	347	-	-	-	16
	20-41	45	126	225	-	-	-	41	-
61-0	24-31	90	225	255	-	-	-	-	31
	24-61	90	180	270	324	150	-	61	-

<u>A</u> 1	<u>PTDS</u> 2	<u>70</u> 3	<u>18</u> 4	<u>32</u> 5	<u>P</u> 6	<u>W</u> 7	<u>L</u> 8	<u>V2</u> 9
	Series	Shell Style	Shell Size	Insert Arrangement	Contact Configuration	Orientation	Modification	Modification

1. Manufacturer Logo

2. Connector Type

3. Shell Type

- 70 Wall Mounting Receptacle
- 74 Jam Nut Receptacle
- 76 Straight Plug
- 78 Lanyard Plug

4. Shell Size

- 12 Size
- 14 Size
- 18 Size
- 20 Size
- 24 Size

5. Insert Arrangement

Refer page No. 6

6. Contact Configuration

- P- Pin Socket
- S- Socket Contact

7. Orientation

- (Omit if normal Orientation)
- Keys/Keyways B Orientation
- For Inserts : W, X, Y & Z
- (Refer page no. 4)

8. Launch Vehicle

9. Version

CLAMP NUT

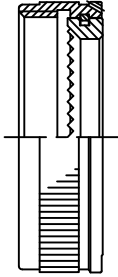

Shell Size		CONN. P/NOS.	
MIL	A IIL		
*	3	10	PTDS-10-BS-416
	7	12	PTDS-12-BS-416
	12	14	PTDS-14-BS-416
*	19	16	PTDS-16-BS-416
	27	18	PTDS-18-BS-416
	37	20	PTDS-20-BS-416
	61	24	PTDS-24-BS-416

Leading Clip

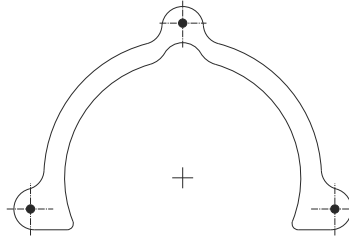

Shell Size		CONN. P/NOS.	
MIL	A IIL		
	3	10	PTDS-76-10-LC
	7	12	PTDS-76-12-LC
	12	14	PTDS-76-14-LC
	19	16	PTDS-76-16-LC
	27	18	PTDS-76-18-LC
	37	20	PTDS-76-20-LC
	61	24	PTDS-76-24-LC

S/R CLAMP BODY

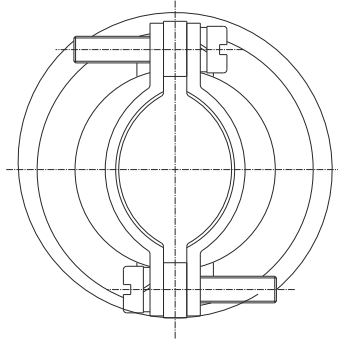
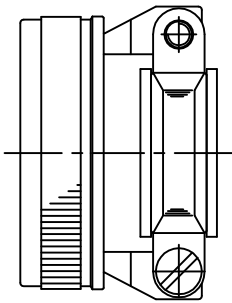

Shell Size		CONN. P/NOS.	
MIL	A IIL		
*	3	10	PTDS-10-SR-416
	7	12	PTDS-12-SR-416
	12	14	PTDS-14-SR-416
*	19	16	PTDS-16-SR-416
	27	18	PTDS-18-SR-416
	37	20	PTDS-20-SR-416
	61	24	PTDS-24-SR-416

POTTING CUP

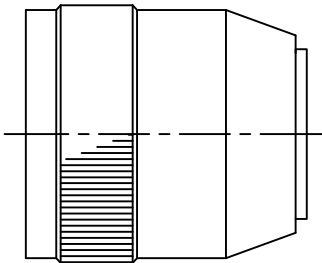

Shell Size		CONN. P/NOS.	
MIL	A IIL		
*	3	10	PTDS-10-PC-416
	7	12	PTDS-12-PC-416
	12	14	PTDS-14-PC-416
*	19	16	PTDS-16-PC-416
	27	18	PTDS-18-PC-416
	37	20	PTDS-20-PC-416
	61	24	PTDS-24-PC-416

S/R ANGLE PLUG

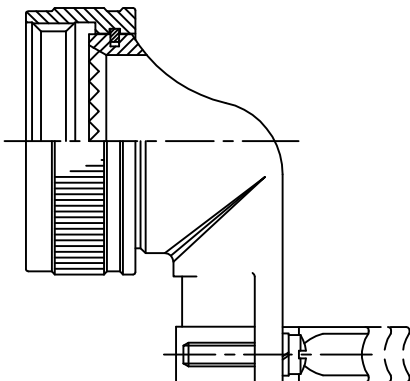

Shell Size		CONN. P/NOS.	
MIL	A IIL		
*	3	10	PTDS-10-RT-416
	7	12	PTDS-12-RT-416
	12	14	PTDS-14-RT-416
*	19	16	PTDS-16-RT-416
	27	18	PTDS-18-RT-416
*	37	20	PTDS-20-RT-416
	61	24	PTDS-24-RT-416

* Consult Factory

NORTH AMERICA

Sales & Product Support

Amphenol PCD
72 Cherry Hill Drive
Beverly, MA 01915 USA
Tel: +1-978-624-3400
Fax: +1-978-927-1513
info@amphenolpcd.com
www.amphenolpcd.com
www.backshellworld.com

Amphenol Aerospace Operations
40-60, Delaware Avenue
Sidney, NY 13838-1395
Tel: +1-607-563-5011
Fax: +1-607-563-5357

Amphenol Canada
Meford Drive
Scarborough,
ON M1B 2X6
Tel: +416-291-4401
Fax: +416-292-0647

Amphenol Fiber Systems International
1300 Central Expressway North
Suite 100 Allen, Texas 75013, USA
Tel: +1-214-547-2400
Fax: +1-214-547-9344

EUROPE

France

Amphenol Socapex S.A.S.
948, Promenade de l'Arve
Bp29, Thyex Cedex
74311, France
Tel: +33-4-5089-2800
Fax: +33-4-5096-1941

United Kingdom

Amphenol Limited
Thanet Way, Whitstable
Kent CT5 3JF, England
Tel: +44-1227-773-200
Fax: 44-1227-276-571

Germany

Amphenol-Air LB GmbH
Am Kleinbahnhof 4
Saarlouis
D-66740, Germany
Tel: 49-6831-9810-00
Fax: 49-6831-9810-30

Italy

Via Barbaiana 5
20020 Lainate (Milano)
Italy
Tel :+39-02-93254.209
+39-02-93254.214
Fax:+39-02-93254-444

Center & East Europe

Amphenol
Wiener Gasse 68
2380 Perchtoldsdorf
Tel: +43-699-10396071
Fax: +43 699 40396071

Amphenol Air-LB
Immeuble Le Doublon
11, Avenue Dobonnet
Courbevoie-Cedex
92407, France
Ph: +33-1-4905-3000
Fax: +33-1-4905-3043

Spain

Amphenol Iberica
Edificio Burgosol Oficina
N 55 C/Comunidad de
Madrid 35 bis -
Las Rozas (Madrid)
Tel: +34-91-6407302
+34-91-6407306
Fax:+34-91-6407307

Austria

Amphenol Austria
Wiener Gasse 68
2380, Erchtoldsdarf,
Austria
Tel : + 43-69910396071
Fax: + 43-69940306071

Holland

Amphenol Benelux
Zadelmaker 121
NL-2401 PD Alphen
aan den Rijn Holland
Tel:+31-172-444903
Fax:+31-172 240254

Sweden

Amphenol
Industrial and Military &
Aerospace
Nordic & Baltic
Military Phone/
Mobile+46702129200
Industrial +46 767909560

ASIA

India

Amphenol Interconnect India Pvt. Ltd.
105 Bhosari Industrial Area
Pune-411026, India
Tel: +91-20-3068-8305
Fax:+91-20-2712-9158

Japan

Amphenol Japan
471-1, Deba, Ritto City
Shiga 520-3041, Japan
Tel: +81-77-553-8501
Fax: +81-77-551-2200

Singapore

Amphenol East Asia Ltd.
72 Bendemeer Road
03-33 Luzerne
Singapore 339 941
Tel: 65-6294-2128
Fax: 65-6294-3522

China

Amphenol PCD Shenzhen
3/F Building, A4 Songbai
Industrial Park
East Road of Minghuan
Gongming Town, Baon District
Shenzhen, China
Tel: +86-755-8173-8000
Fax: +86-755-8173-8180

Amphenol Interconnect India Pvt. Ltd.
61 Electronics City
Bangalore-560 100, India
Ph: +91-80-2852-3838
Fax: +91-80-2852-0418

Korea

Amphenol Daeshin Electronics
558 SoSa, SongNae, Bucheon-City
Kyunggi-Do, Korea 420-130
Tel: +82-32-610-3800
Fax: +92-32-673-2507

ROW

Australia

Amphenol Australia Pty Ltd
2 Fiveways Boulevard
Keysborough
VIC 3173
Ph: +61-3-8796-8888
Fax: +61-3-8796-8801

Africa

Amphenol South Africa
30 Impala Road
2196 Sandton-Chistlehurst
South Africa
Tel: +27-11-783-9517
Fax: +27-11-783-9519

Russia

Amphenol Russia
8-2 Yaroslavskaja Str
129164 Moscow, Russia
Tel: +7-495-937-6341
Fax: +7-495-937-6319

Argentina

Amphenol Argentina
Avenida Callao 930
2nd Floor, Office B Plaza
C1023AAP Buenos Aires
Argentina
Tel: 54-11-4815-6886
Fax: 54-11-4814-5779

Israel

Bar-Tec Ltd.
P.O. Box 279
Kfar Sava, 44102 Israel
Tel: +972-9-7644100
Fax: +972-9-7674324

Maslak

34396 Istanbul
Tel: +90-212-335-2501
Fax: +90-212-335-2500

Brazil

Amphenol do Brasil Ltda
Rua Diogo Moreira 132
CEP 05423-010
Sao Paulo-SP, Brazil
Tel: +55-11-3815-1003
Fax: +55-11-3815-1629

Amphenol

A Global Company



Pune Operations



Bangalore Operations

Amphenol

Interconnect India Pvt. Ltd.

Manufacturing Locations

Corporate Office & Pune Factory

105, Bhosari Industrial Area,
Pune - 411 026.
Tel.: 91- 20 - 67360302
Fax : 91- 20 - 67360321
rjohn@amphenol-in.com

Exports

Tel.: 91- 20 - 67360305, 67360353
Email : svpatil@amphenol-in.com

Bangalore Factory

61 Keonics Electronic City
Hosur Road, Bangalore 560 102
Mobile : 91-66790900 /910 /937
Email : shrikantgramopadhye
@amphenol-in.com

Marketing Locations

Marketing Headquarters

Tel.: 91- 20- 67360303, 67360304
Fax : 91-20- 67360321
Email : vbhavsar@amphenol-in.com
sales@amphenol-in.com

Western Region

Tel.: 91-20-67360334
Email : sunilp@amphenol-in.com

Northern & Eastern Region

A-421, Pacific Business Park
Plot No. 37/1, Sahibabad Indst. Area
Site IV, Ghaziabad (UP) - 201 010.
Mobile : 91-9910211399
Email : sunily@amphenol-in.com

Southern Region

No. 1115, 22nd Main Road,
11th Cross Sector-1, HSR Layout
Bangalore 560 102
Tel.: 91-80-49530341, 49530345
Fax : 91-80-49538697
Email : kmanoj@amphenol-in.com

Central Region

107, 1st Floor, 'Am Sri Classic',
Sarojinidevi Road, Secunderabad-500 003.
Telefax : 91- 40-66332906
Email : pprasad@amphenol-in.com

www.amphenol-in.com