

PLUG WITH INTEGRAL STRAIN RELIEF

38999+ CONNECTORS

PDS - 289

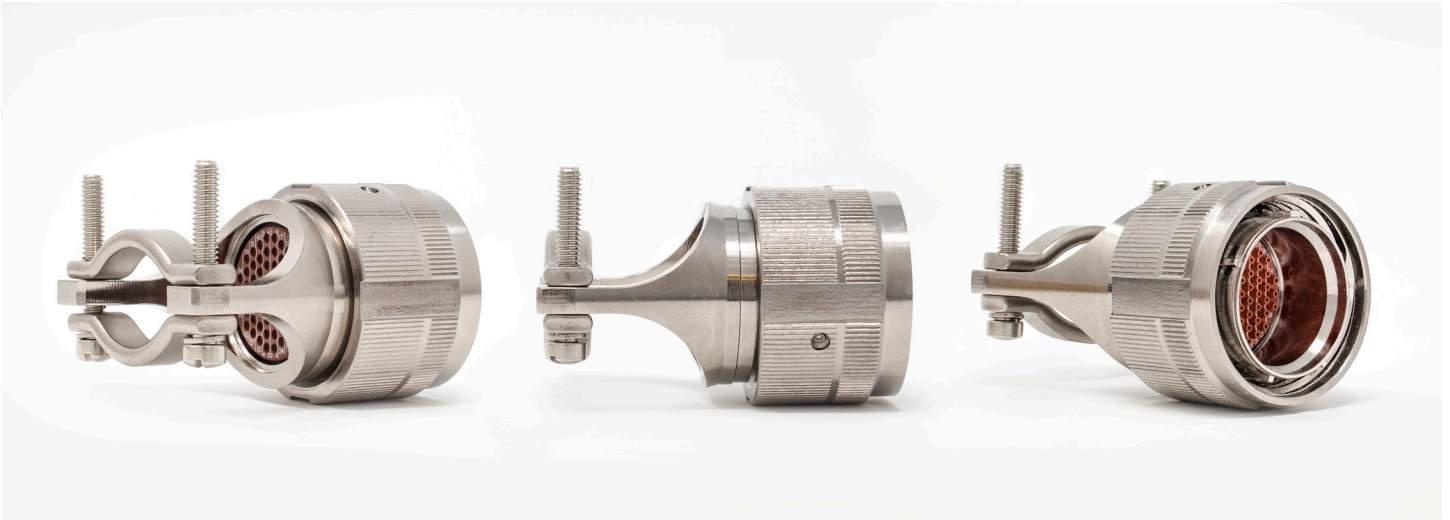

The MIL-DTL-38999 Series III style plug features an integral strain relief design that eliminates the need for an additional backshell accessory.

The strain relief feature is incorporated into the rear of the connector shell, allowing the user to reduce stress on the connector, insert, and contacts with a one piece shell design. This solves the problem of accessory backoff found throughout the aerospace industry. The straight plug with integral strain relief is available in aluminum and stainless steel shells with standard Amphenol platings.

FEATURES & BENEFITS:

- Eliminates accessory backoff concerns
- Eliminates need for additional accessory
- Eliminates industry problem of misaligned accessory teeth
- Time savings throughout order placement and installation processes
- Space and weight savings
- Available in aluminum and stainless steel with all standard Amphenol platings

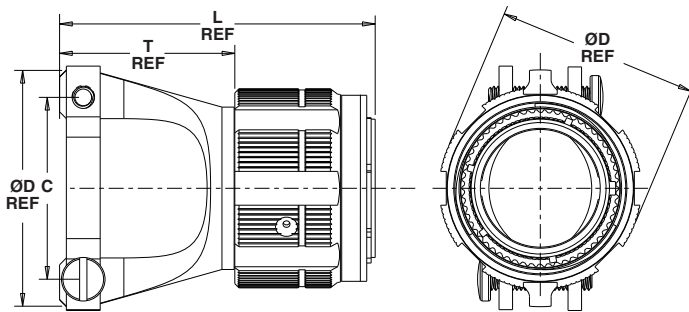

Shell Size	MS Shell Size Code	A Max.	C	D DIA REF	L REF	T REF
9	A	0.859	0.688	0.950	1.890	0.815
11	B	0.969	0.812	1.110	1.985	0.910
13	C	1.141	0.945	1.270	2.080	1.005
15	D	1.266	1.062	1.430	2.175	1.100
17	E	1.391	1.250	1.590	2.270	1.195
19	F	1.500	1.344	1.750	2.365	1.290
21	G	1.625	1.500	1.880	2.490	1.415
23	H	1.750	1.656	2.010	2.615	1.540
25	J	1.875	1.781	2.150	2.740	1.665

BUILD A PART NUMBER: TVS76RF-15-35PA

Complete steps 1-7 to create your part number

1.	2.	3.	4.	5.	6.
Connector Type	Shell Style	Service Class	Shell Size - Insert Arrangement	Contact Type	Alternate Position
TVS	76	RF	15-35	P	A

STEP 1 : Choose a Connector Type

Connector Type	
TV	Tri-Start 175°C
TVS	Tri-Start 200°C

STEP 2 : Choose Shell Style

Shell Style	
76	Plug with Integral Strain Relief

STEP 3 : Choose a Service Class

Service Class		
RF	Electroless nickel plated aluminum EMI shielding effectiveness - 65dB @ 10GHz specification min., 48 hour salt spray, 200°C	
RK	Corrosion resistant stainless steel, firewall capability, plus 500 hour salt spray resistance, EMI -45dB @ 10GHz specification min., 200°C	
RL	Corrosion resistant steel, electro deposited nickel, 500 hour salt spray, 200°C, non firewall, EMI shielding -65dB @ 10GHz specification min.	
RS	(Non-hermetic connectors), Nickel plated, corrosion resistant steel, firewall capability, 500 hour salt spray, 200°C, EMI shielding -65dB @ 10GHz specification min.	
RW	Corrosion resistant olive drab cadmium plated aluminum, 500 hour extended salt spray, EMI -50dB @ 10GHz specification min., 175°C	
DT	Durmalon plated, alternative to cadmium. Corrosion resistant, 500 hour extended salt spray, EMI -50dB @ 10GHz specification min. without CR6	
DZ	Black Zinc-Nickel alternative to cadmium. Corrosion resistant, 500 hour salt spray, conductive, -65°C to +175°C	
DW	Corrosion resistant olive drab cadmium plated aluminum, 1,000 hour extended salt spray, EMI -50dB @ 10GHz specification min., 175°C	

STEP 5 : Choose a Contact Type

Contact Type	
P	Pin
S	Socket
H	1,500 Cycle Pin Contacts
J	1,500 Cycle Socket Contacts

STEP 6 : Choose an Alternate Position

Alternate Position	
	<i>Blank for normal rotation</i>
A	A rotation
B	B rotation
C	C rotation
D	D rotation
E	E rotation

STEP 4: Select a Shell Size & Insert Arrangement

Shell Size - Insert Arrangement
<i>See Amphenol Catalog page 2-13</i>