



TFOCA-II® EX Plug & Receptacle

About the TFOCA-II® EX Connector

Amphenol Fiber Systems International (AFSI) offers the TFOCA-II® EX connector to provide fiber optic connectivity in Zone 1 and Zone 21 hazardous environments. AFSI was awarded an ATEX certification number (09ATEX1033X) from Sira for its fiber optic 4-channel TFOCA-II® hermaphroditic plug and receptacle connectors. This certification allows TFOCA-II® EX connectors to mount directly to flameproof enclosures in hazardous environments, providing a safe, robust and user-friendly fiber optic interface.

The TFOCA-II® EX is ideal for instrumentation and control systems located in petrochemical production, exploration and process facilities. The TFOCA-II® EX eliminates the need for hard-wired fiber optic cable glands, reducing deployment, maintenance and tear down time. Also, when compared to hard-wired cable glands, the equipment can be connected and disconnected by minimally-trained personnel.



The TFOCA-II® EX was specifically designed for fiber optics using field-proven TFOCA-II® technology. The standard TFOCA-II® EX supports up to four single mode or multi-mode fiber optic contacts. Using precision ceramics, the TFOCA-II® EX provides excellent optical performance with insertion losses of 0.3 dB typical and 0.75 dB maximum. The connector is also easy to terminate with standard fiber optic tools and training.

Features & Benefits

- Allows direct mount to explosion-proof rated enclosures reducing deployment and tear down times
- Allows equipment deployment by minimally-trained personnel
- Specifically designed for fiber optics using field-proven TFOCA-II® technology

Applications

- Hazardous environments in petrochemical refineries
- Oil & Gas drilling platforms
- Power plants
- LNG terminals

Ordering Nomenclature

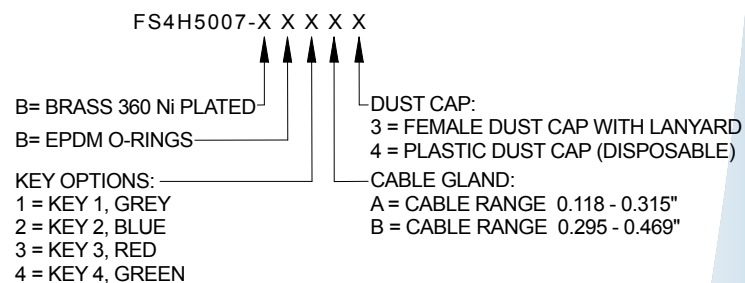

EXAMPLE: FS4H5007-B B1A3
RECEPTACLE ASSEMBLY, 1" NPT, EXTERNAL MOUNT, TFOCA-II® 4-CH WITH:
C36000, BRASS 360, 1/2 HARD, NICKEL PLATED, EPDM O-RINGS, KEY OPTION 1,
CABLE RANGE 0.118-0.315", BRASS FEMALE DUST CAP

TFOCA-II® EX Dimensional and 3D Drawings

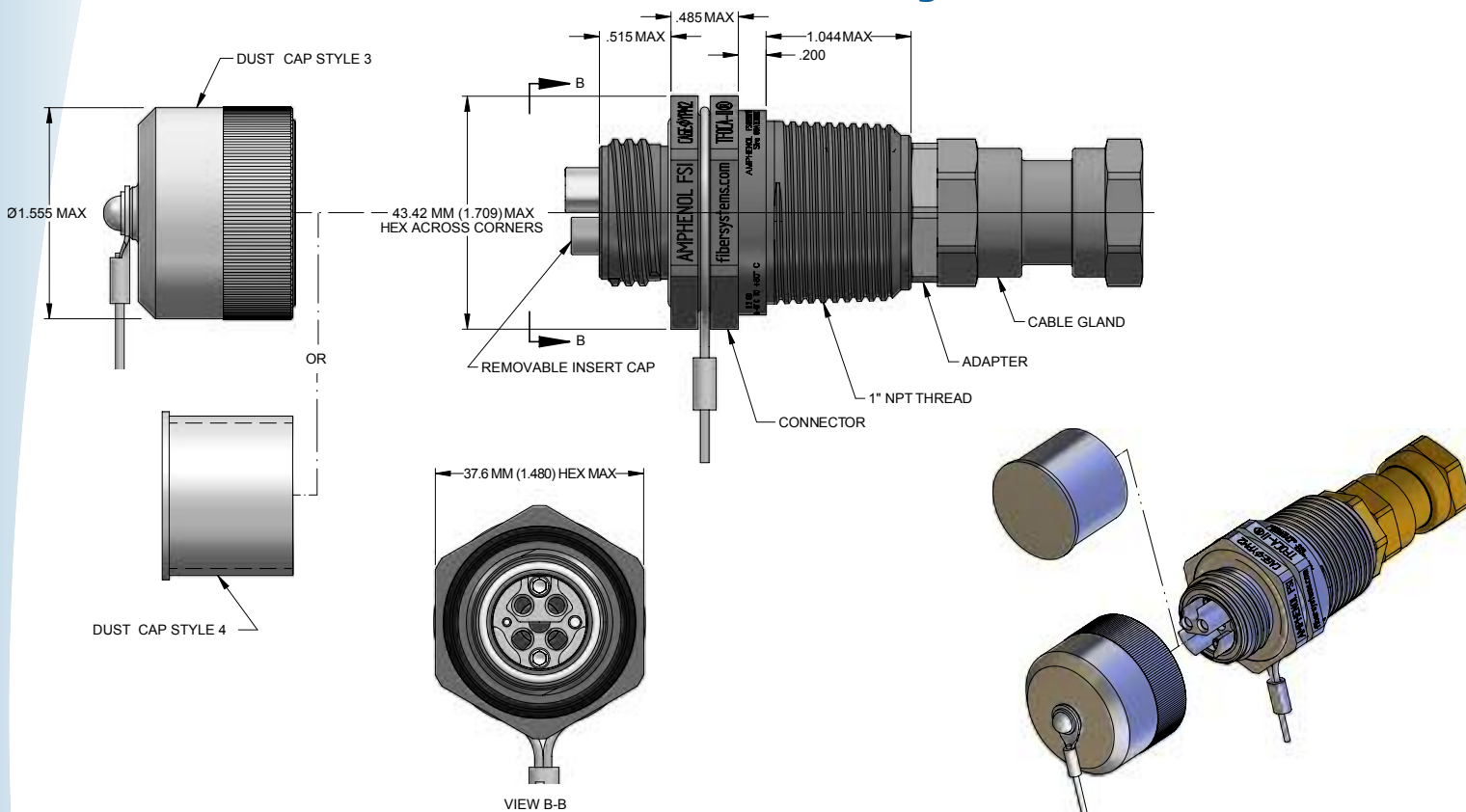

TFOCA-II® EX Specifications

Parameter	Typical	Maximum
Insertion Loss (Multimode)	0.30 dB	0.75 dB
Insertion Loss (Single Mode)	0.40 dB	0.75 dB
Back Reflection (Single Mode-UPC Polish)	-50 dB	-40 dB
Operating Temperature	-46° C to + 71° C	
Storage Temperature	-52° C to + 85° C	
Mud	5 minute immersion, clean with water (per MIL-C-83526/12 /13 requirements)	
Water Pressure	MIL-STD-810, Method 512.4, 1 m, 48 hr	
Ice Crush	DOD-STD-1678, Method 4050	
Humidity	DOD-STD-1678, Method 4030, 10 cycles	
Flammability	MIL-STD-1344, Method 1012	
Vibration (Operational)	MIL-STD-1344, Method 2500.1	
Shock	EIA/TIA-455-14, Condition A	
Mating Durability	2,000 cycles per EIA/TIA-455-21	
Cable Seal Flexing	100 cycles per MIL-STD-1344, Method 2017, Procedure 1	
Twist	1,000 cycles per EIA/TIA-455-36	
Cable Retention	400 lb min per EIA/TIA-455-6, 1hr (plug & strain relief receptacles)	
Impact	EIA/TIA-455-2	
Crush Resistance	450 lb min per EIA/TIA-455-26	
EMI Shielding Effectiveness (Receptacle Only)	> 60dB, 15 KHz to 10 GHz	
Corrosion Resistance	MIL-STD-1344, Method 1001, Condition A	